

IMMERSION COOLING BOILER PLATES

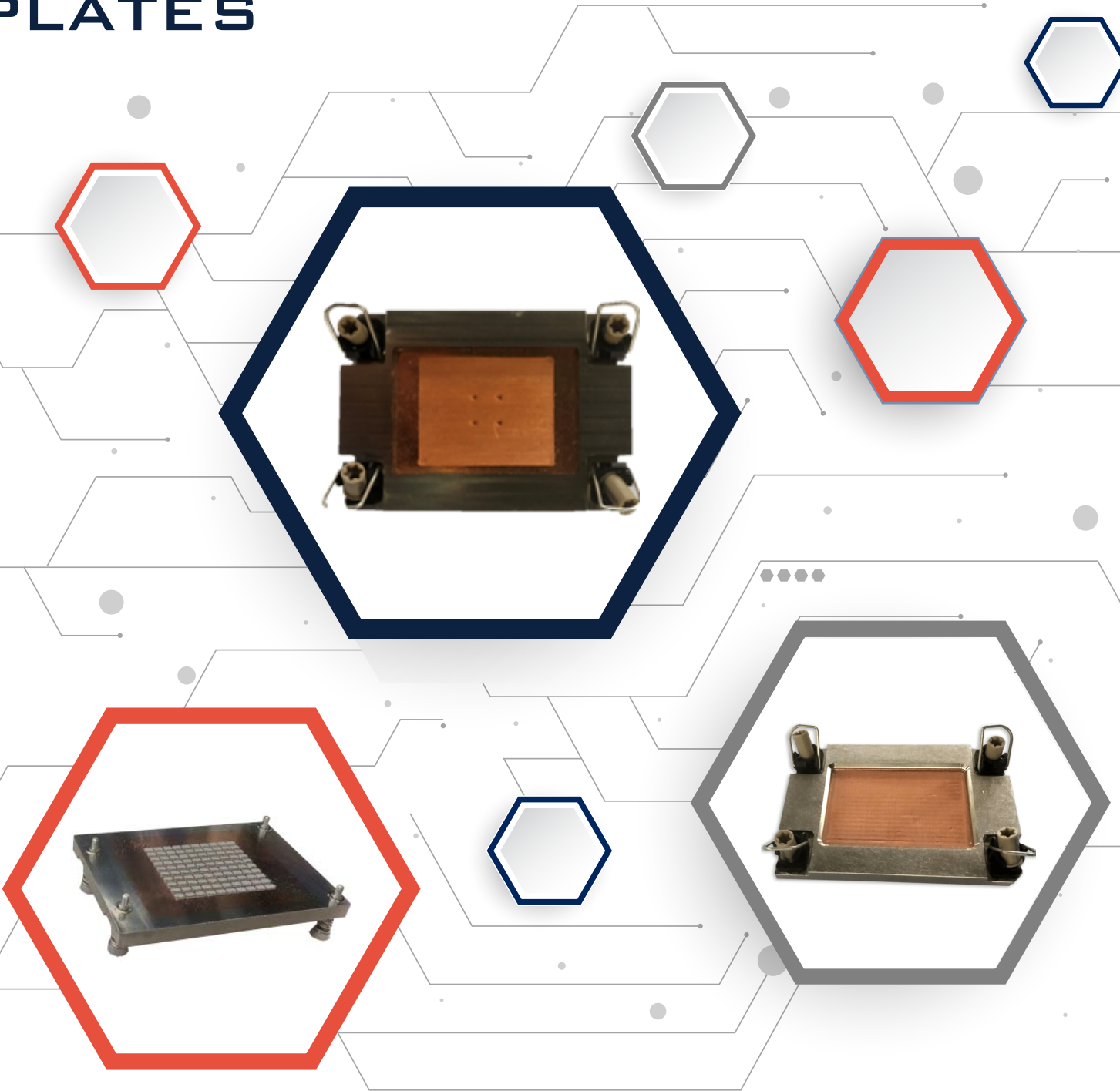

One Company, Many Solutions



Immersion Cooling Boiler Plates

Boyd's Immersion Cooling Boiler Plates cool high heat flux components like CPUs and GPUs when immersed in a tank of optimized dielectric fluid. Improvements in cooling capacity enable increased processing power and electronic density compared to other cooling technologies. Two phase immersion eliminates complex air flow management and tube routing required in air or direct liquid systems. Immersion cooling reduces hardware requirements, shortens development cycles, and simplifies assembly. All components have access to cool ambient liquid without any preheat from upstream components for immediate cooling and balanced temperatures. Leveraging passive heat transfer within the rack or tank eliminates local pumps and fans requirements which provides quieter environments with increased noise safety. Immersion systems reduce moving parts and limit non-IT power consumption from fans and offer a highly reliable and efficient cooling solution.

What is Immersion Cooling?

PCBs with low and high heat flux components are surrounded by dielectric liquid such as 3M™ Fluorinert™ or Novec™ Engineered fluids. Boiler Plates coated with BEC (Boiling Enhancement Coating) are installed on higher heat flux components to reduce the boiling resistance and meet the heat flux of those critical components. The bubbles carry heat to the surface of the pool, where the vapor then condenses on a cooling coil and falls into the pool.

How do Boiler Plates Work?

Immersion Boiler Plates are mounted to high heat flux devices like CPUs and GPUs to conduct heat to a Boiling Enhancement Coating (BEC). The BEC is optimized to initiate and enhance boiling of the immersion fluid and rapidly replenish liquid to the boiling surface. Immersion Boiler Plates minimize the temperature differential between the device and the immersion fluid, enabling cooler operating temperatures and higher processing speeds. Boyd has developed multiple BEC types with different critical heat flux limits and thermal resistance to obtain the best fit for the application. Beyond our standard boilers, Boyd's two-phase experts can help you select and optimize the right base, BEC style, and mounting hardware to best meet your system performance requirements.

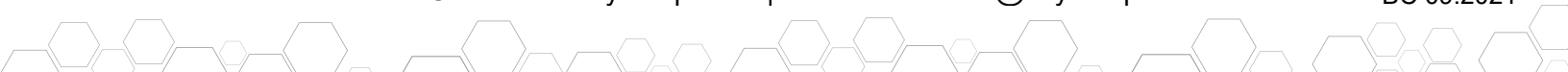
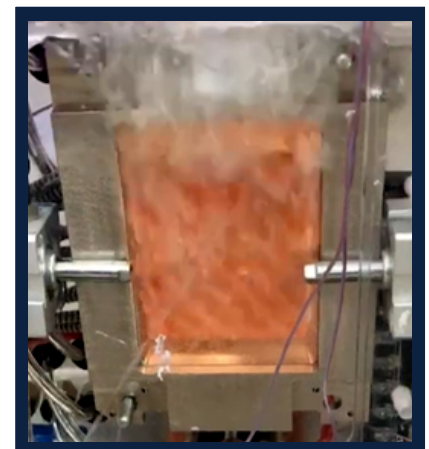
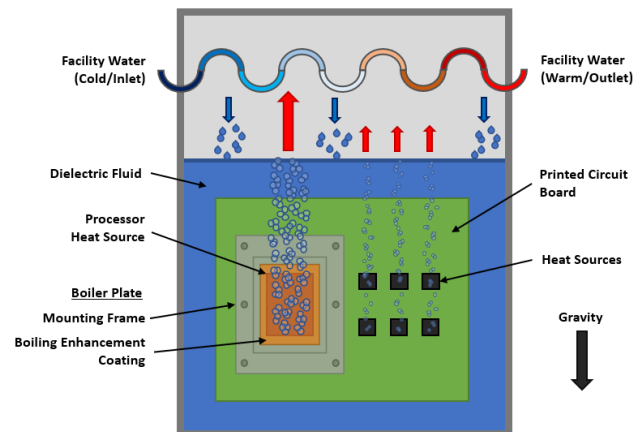



Boyd Reference Designs

Boyd has developed and optimized numerous Boiler Plates for many of today's highest power and highest heat flux components. These boilers have been tested by Boyd and early adopters of this technology to work with most SKU's for the devices shown below. Although custom solutions have been created with customized hardware, BEC coatings, vapor chamber bases, etc. it is recommended to start with these reference designs for any initial development.

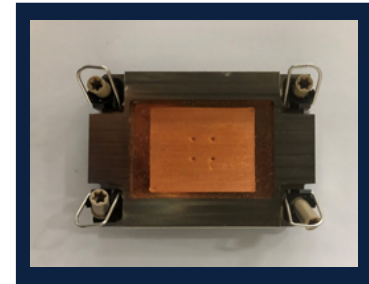

Chip Manufacturer	Chip Codename	Platform, Socket, or Package	Boyd P/N	Boiler Plate Power Range (W)	BEC Type
AMD™	EPYC™ 7002 - series (Zen 2 - ROME) EPYC™ 7003 - series (Zen 3 - MILAN)	SP3	669257	150 - 400	GEN 2
AMD™	Zen 4 - GENOA	SP5	692090	200 - 600	GEN 2
Intel®	Xeon® up to Platinum 8000-Series (SKL - Skylake)	LGA-3647 (Purley)	063528	100 - 300	GEN 1
Intel®	Xeon® up to Platinum 9200-Series (CLX-AP, Cascade Lake Advanced Performance)	BGA-5903	684512	100 - 300	GEN 2
Intel®	Xeon up to Platinum 8300-Series (ICX - Ice Lake SP)	LGA-4189 (Whitley)	677229	150 - 350	GEN 1
Intel®	(SPR - Sapphire Rapids)	(EGS - Eagle Stream)	680263	200 - 600	GEN 2
NVIDIA™	Tesla P100	SMX2	686439	200 - 550	GEN 2

NOTE: Immersion Boiler Plates are installed with high performance thermal grease and tested in various fluids such as HFE 7100, FC-72, and FC-3284.

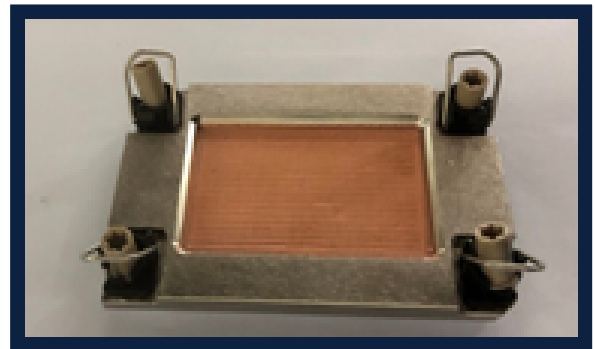
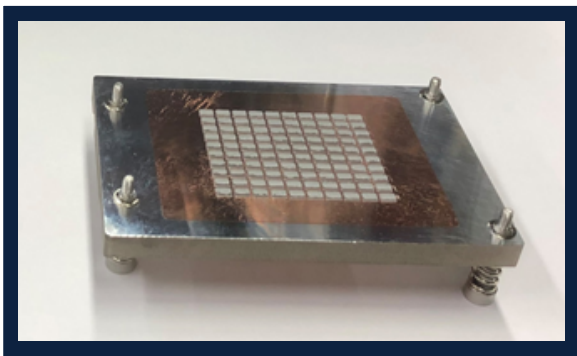

NOTICE:

The information included in this data sheet is believed to be accurate and reliable. BOYD Corporation assumes no responsibility for end use applications and no performance warranty is expressed or implied.

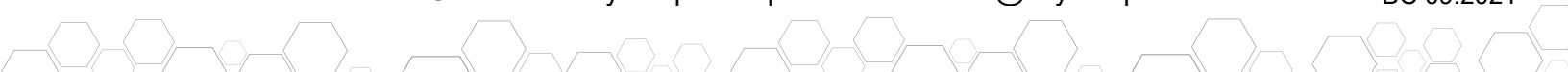



Mechanical Specifications

Boyd's Boiler Plates come pre-assembled with AMD™, Intel®, NVIDIA™ and other CPU and GPU compatible hardware and pre-applied with thermal grease for easy installation. Boyd reference designs below should be used as a starting point for your evaluation. Custom-designed immersion Boiler Plates can be created to meet application specific requirements.

669257 - AMD™ - EPYC™ Zen 2 - ROME and Zen 3 - MILAN (SP3)

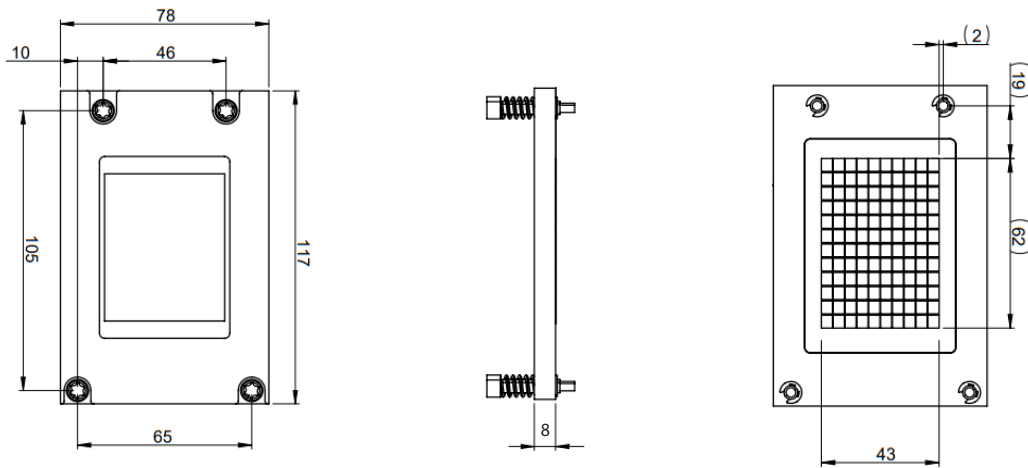

692090 - AMD™ - Zen 4 - GENOA (SP5)

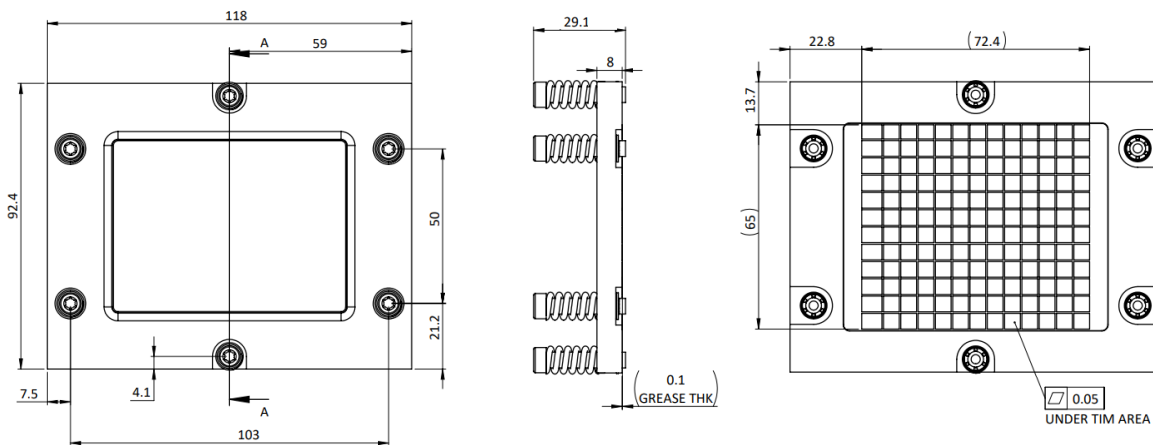

NOTICE:

The information included in this data sheet is believed to be accurate and reliable. BOYD Corporation assumes no responsibility for end use applications and no performance warranty is expressed or implied.

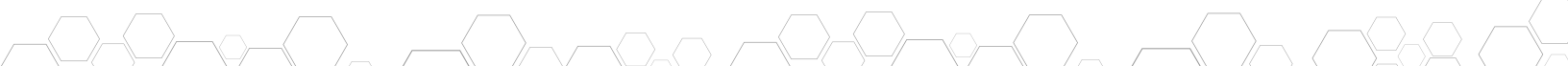



Mechanical Specifications

063528 - Intel® - Xeon® SKL - Skylake (Purley)

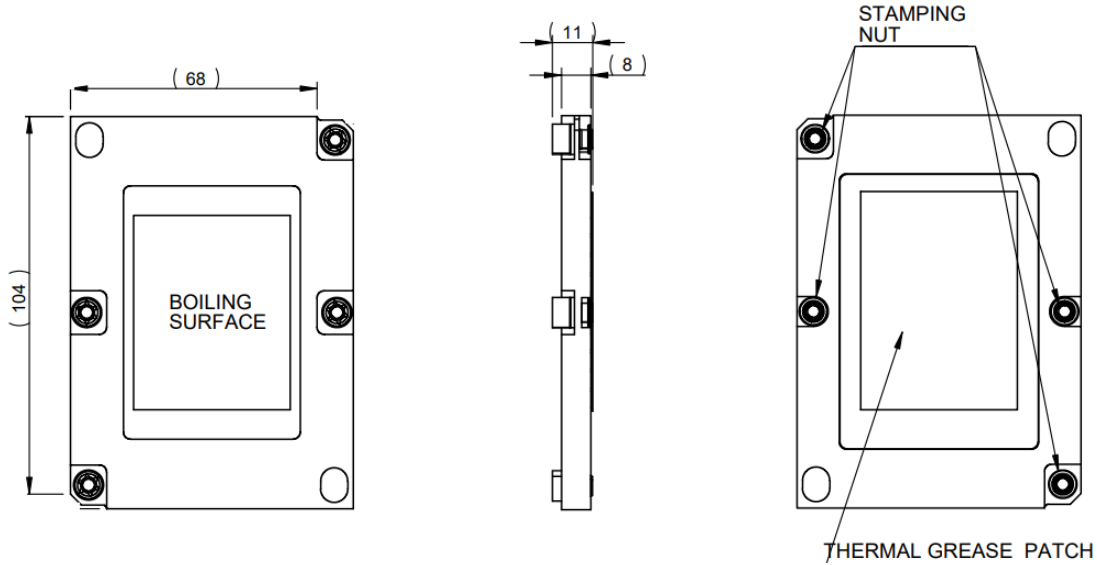

684512 - Intel® - Xeon® - CLX-AP - Cascade Lake Advanced Performance (BGA-5903)

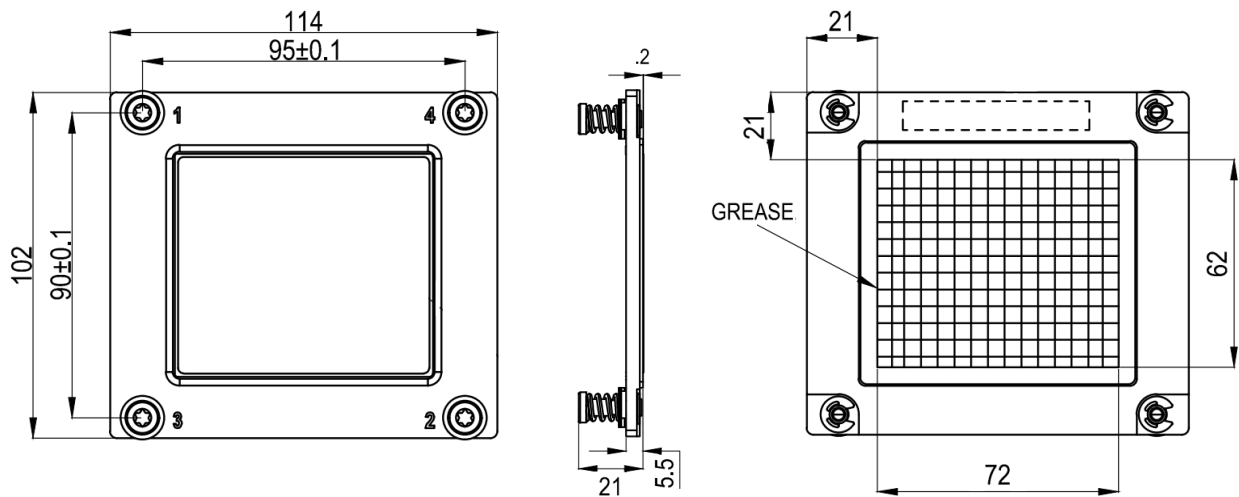

NOTICE:

The information included in this data sheet is believed to be accurate and reliable. BOYD Corporation assumes no responsibility for end use applications and no performance warranty is expressed or implied.

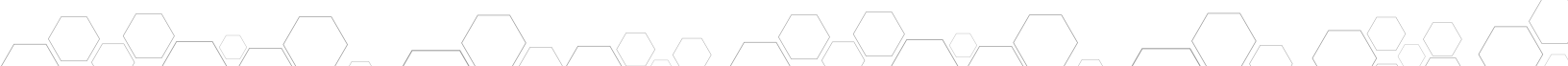



Mechanical Specifications

677229 - Intel® - Xeon® - ICX - Ice Lake SP (Whitley)

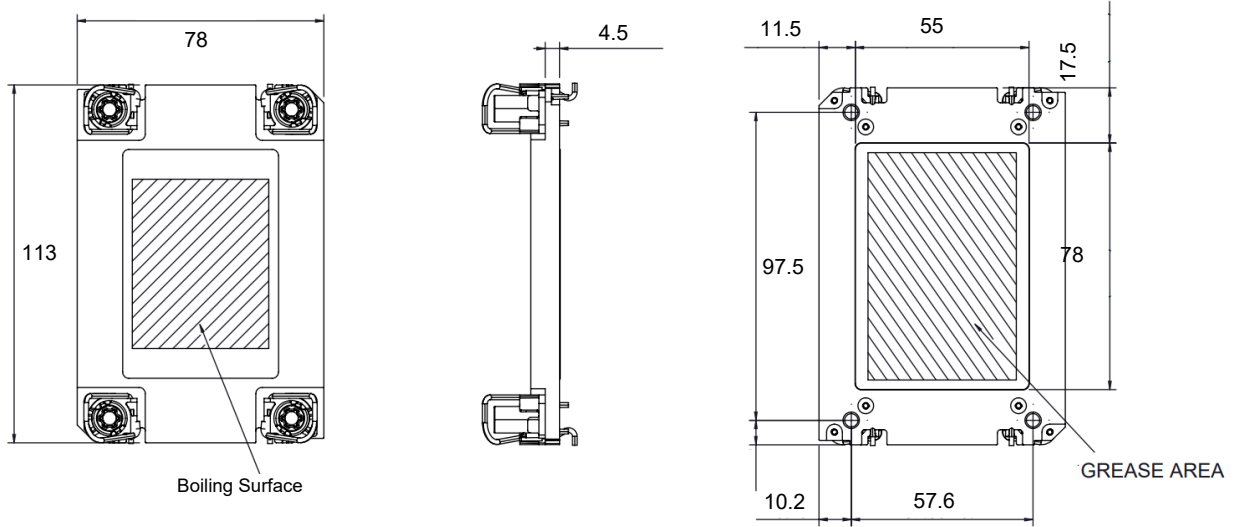

680263 - Intel® - SPR - Sapphire Rapids (EGS - Eagle Stream)

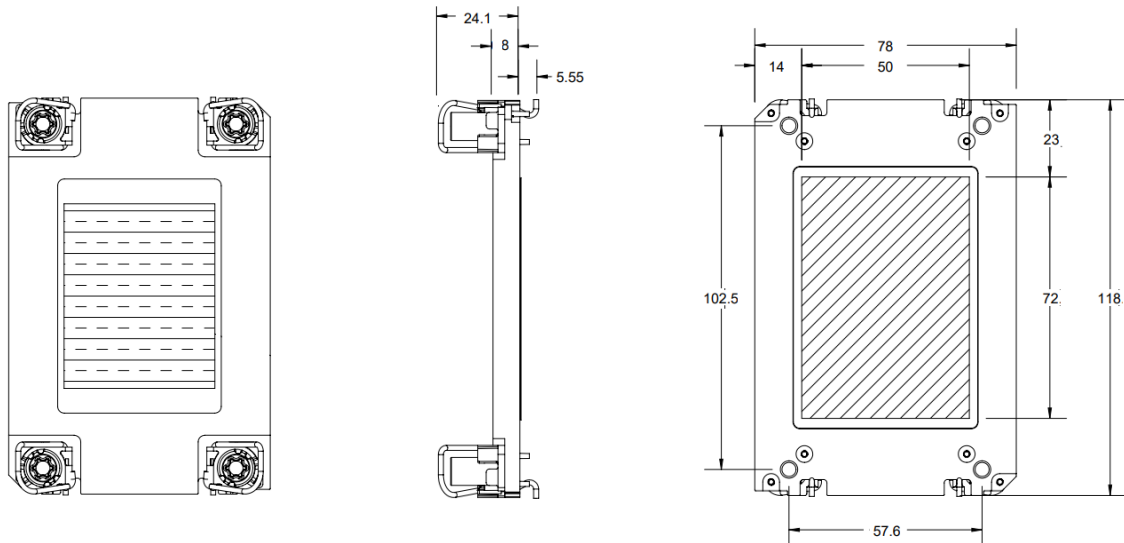

NOTICE:

The information included in this data sheet is believed to be accurate and reliable. BOYD Corporation assumes no responsibility for end use applications and no performance warranty is expressed or implied.

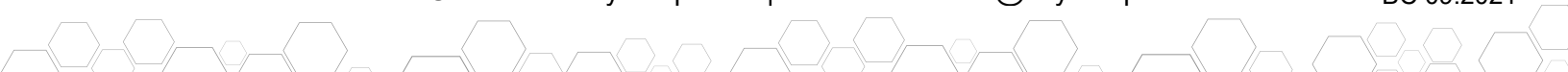



Mechanical Specifications

686439 - NVIDIA™ - Tesla P100 (SMX2)

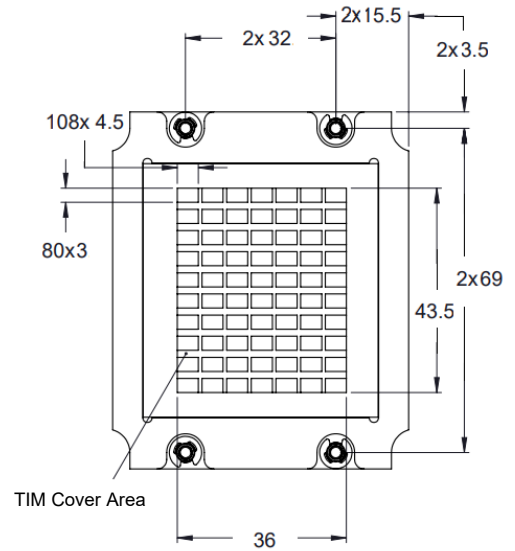
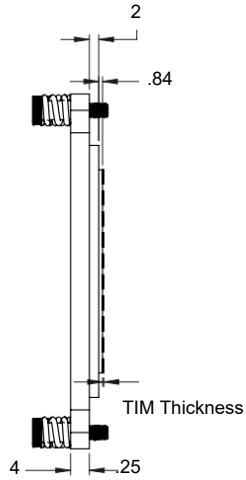
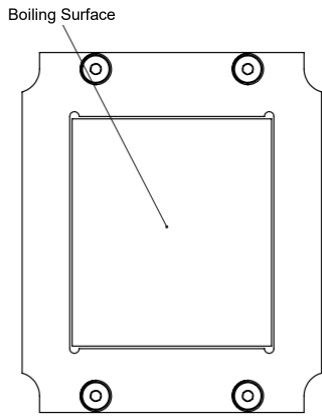

NOTICE:

The information included in this data sheet is believed to be accurate and reliable. BOYD Corporation assumes no responsibility for end use applications and no performance warranty is expressed or implied.

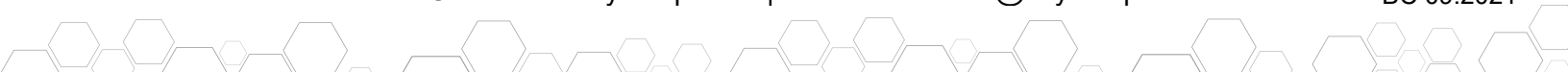

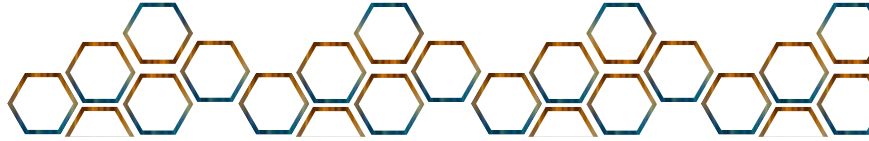

Mechanical Testing

Boyd validates all immersion Boiler Plate solutions to pass mechanical and similar requirements as we would for other thermal solutions such as Air-Cooled Heat Sinks and Liquid Cold Plates.

Stiffness

Example: Stiffness test for Intel® - Xeon® - ICX - Ice Lake SP (Whitley):

Test Conditions:

Equipment: Longwin Stiffness Tester
Test Method: Short span distributed load
Stiffness Requirement: > 1000 lbf/mm

Test Results:

Stiffness: > 1600 lbf/mm

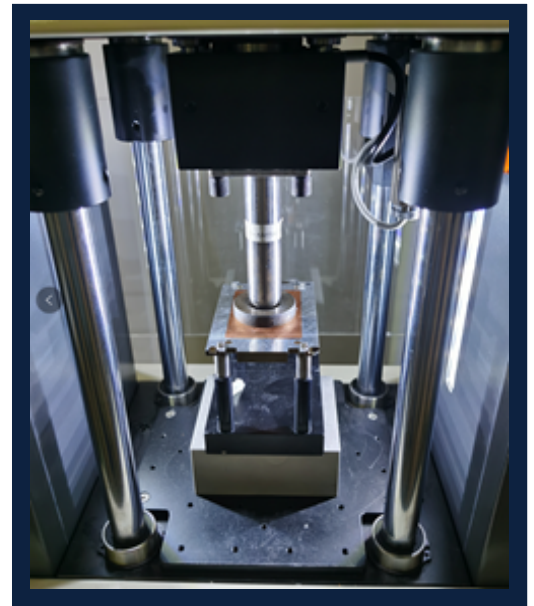

NOTICE:

The information included in this data sheet is believed to be accurate and reliable. BOYD Corporation assumes no responsibility for end use applications and no performance warranty is expressed or implied.

Global Presence

Corporate Headquarters

5960 Inglewood Dr. Suite 115
Pleasanton, CA 94588
+1(888)244-6931

Boyd North America

Our highly-trained North American support teams are here to assist with your program management requirements, material selections, product design, commodity management, application engineering and raw material or finished goods testing. Our cross-functional team can be tailored to your unique needs and will closely monitor your initiatives and new programs, while ensuring tight management of new product introduction, volume production and delivery deadlines.

Alabama • Arkansas • California (4) • Connecticut • Georgia • Indiana • Juarez • Michigan • New Hampshire
New York • North Carolina • Oregon • Pennsylvania • South Carolina • Tennessee • Washington • Wisconsin

Boyd Europe

Our engineers have decades of research and development experience to provide European customers with the highest quality custom technologies. Boyd excels in rapid prototyping and regional design services deployed for global mass production. We offer sophisticated order management that caters to your custom EDI or supply portal needs with just-in-time stocking and delivery support. Boyd delivers high touch customer service in a global environment, optimized for your complex value chains.

Italy • Germany • United Kingdom

Boyd Asia

With operations spread across Asia, Boyd's global manufacturing footprint, engineering design centers and clean room capabilities from Class 100 to Class 100,000 provide consistent quality, speed and cost-effectiveness with centers of excellence and quality management systems to meet the unique needs of highly diversified industries, providing Asia-Pacific customers as well as global OEMs reliability throughout the product life cycle.

Bac Ninh • Bangalore • Chonburi • Donguan • Gujarat • Gumi • New Taipei • Noida • Shanghai • Shenzhen • Singapore • Wuxi