

# *The Max Clip System™*

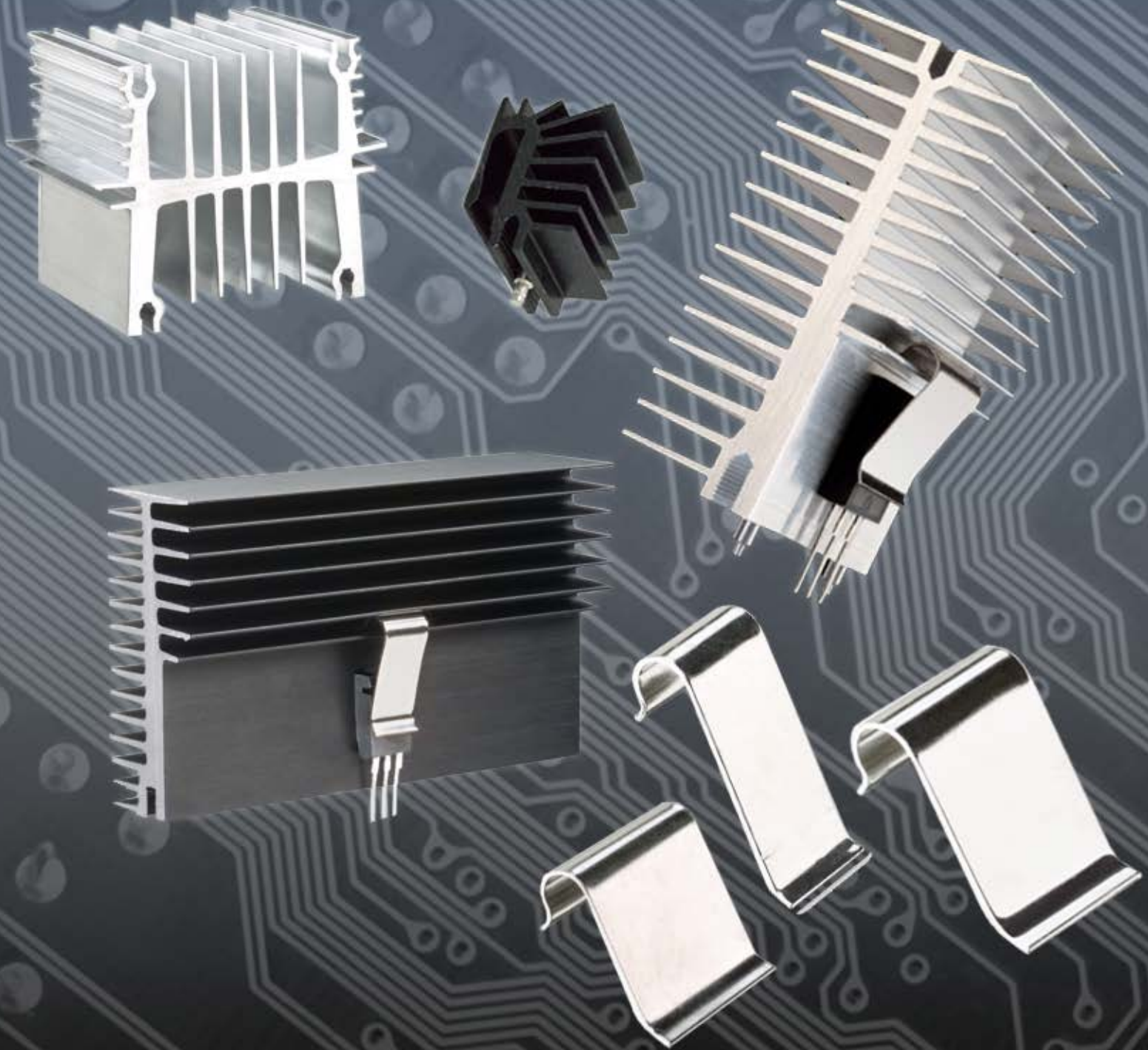

*Complete Thermal Management Solutions*

- How to Use this Catalog ..... 2
- How to Order The Max Clip System™ ..... 3
- The Max Clip System™ Advantages ..... 4
- The Max Extrusion Index ..... 5-6
- The Max Clip System™ Profiles ..... 7-22
  - Single Mounting Surface ..... 7-12
  - Dual Mounting Surface ..... 13-15
  - Max Heat Connector ..... 16-18
  - Single Mounting Surface with Flatback ..... 19
  - U-Channel/Multiple Screw Boss ..... 20
  - Potential Max Profiles ..... 21-22
- The Max Clip System™ Clip Index ..... 23-25
- The Max Clip System™ Clips ..... 26-28
  - Standard Clips ..... 26-27
  - U-Clips ..... 28
- Max Clip Assembly Ideas ..... 29
- Semi-Automated Assembly ..... 30-31
- Chief Extrusion Profiles ..... 32-33
- Solderable Pins ..... 34
- Thermal Performance ..... 35
- Shock & Vibration Testing ..... 36
- Extrusion Standard Tolerances ..... 37

## Max Extrusions

Base extrusion part number  
For ordering information see page 3

Extrusion weight  
kilograms per meter

Thermal resistance in  
natural ( $\theta_n$ ) and forced ( $\theta_f$ ) convection environments  
See notes on page 5 for thermal resistance definitions

**78015**      kg/m: 1.38 •  $\theta_n = 2.46 \text{ }^\circ\text{C/W}$  •  $\theta_f = 0.65 \text{ }^\circ\text{C/W}$

• One slot for vertical mounting to board

Bullet illustrates differentiating features for each Max profile

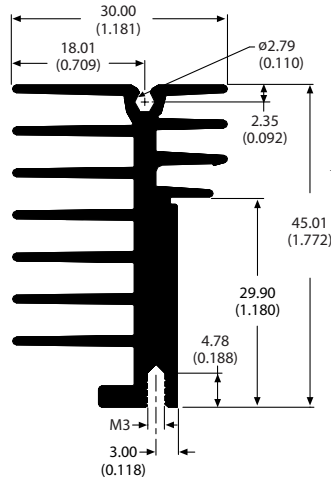

Mechanical drawing illustrating cross section of an extrusion  
Dimensions are mm (inches)

## Max Clips

Clip part number  
For ordering information see page 3

Clip force equation  
(clip width) x (thickness) = force in newtons

**Max03-H**      Width      Thickness      Force  
18 mm      x      0.6      = 80 N

Clip width (not shown in profile view below)

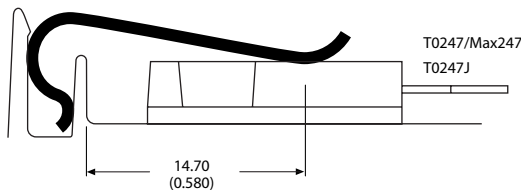

Mechanical drawing showing profile of clip, extrusion and device with contact point dimensions

To select a clip appropriate for the device cooled and the selected profile see the Clip Index on pages 23–25.

## How to Order The Max Clip System™

### General Information:

Extrusions are available in standard bar lengths of 2.5 meters/8.2 feet.  
 Extrusions are unfinished and may be ordered with a black anodize finish.  
 The standard tolerance of all cut to length extrusions is ±0.015 inches.

### Max Extrusion Profiles

Extrusions are ordered using a 12 digit part number as shown below.

**78040 X X XXXXX**

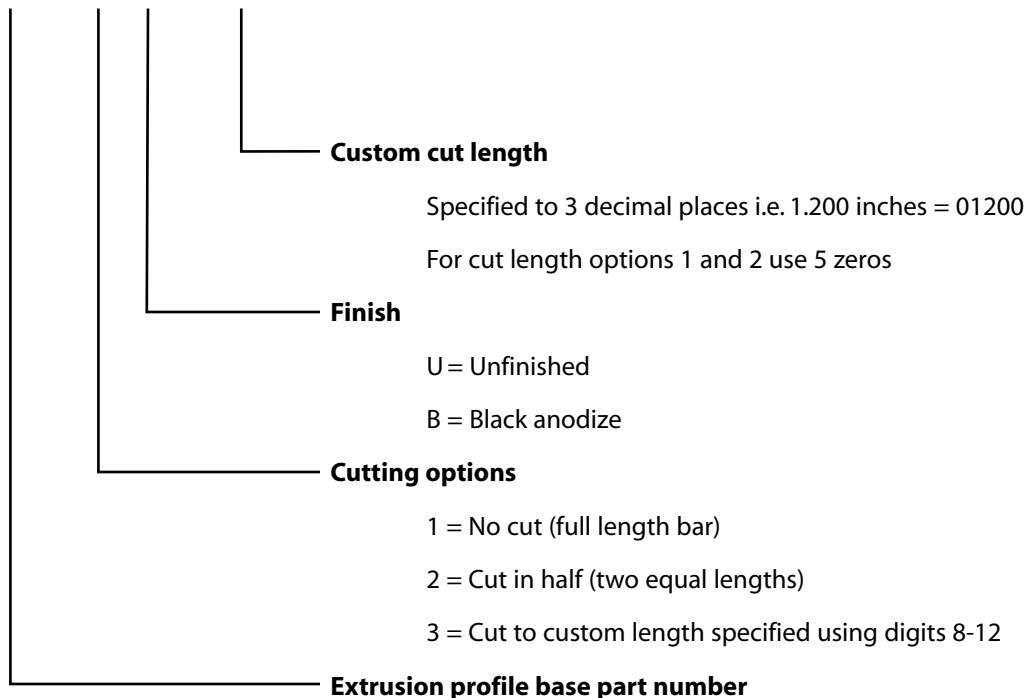

### Max Clips

Clips are ordered separately using the part number shown in the mechanical drawing header information. See How to Use this Catalog on page 2.

### Potential Max Profiles

The Max Clip System™ is only limited by the imagination. For custom solutions or more information on the Potential Max Profiles listed on pages 21 and 22, please contact your local sales representative.

# The Max Clip System™

## MINIMIZE LABOR...MAXIMIZE PERFORMANCE

The Max Clip System™ for discrete power semiconductors is a high performance, low cost thermal solution that eliminates mounting holes, screws, rivets, and the thermal inefficiency associated with using loose hardware to attach components to a heat sink. This quick, robust attachment method saves on labor and hardware costs while increasing performance and design flexibility.

The Max Clip System™ is also the most effective system for mounting power devices in packages that have no mounting holes. Max Clips apply consistent optimum pressure at the center of the semiconductor, improving contact with the heat sink for better thermal performance and maximum component reliability. Aavid offers approximately 50 extrusion profiles that accept over 20 different Max Clips to suit your application. The Max Clip System™ is designed to accommodate a variety of semiconductor packages including TO-220, TO-218, TO-247, TO-3P, and packages without mounting holes like TO-262, TO-273, TO-274, and TO-251.

### Features and Benefits of The Max Clip System™ include:

- *Optimizes thermal management of power transistors*
- *Provides mounting for discrete power devices with or without mounting holes*
- *Reduce labor costs by eliminating the need for drilled or tapped holes in heat sinks*
- *Allows flexibility for moving or changing devices*
- *Provides consistent mounting force for reduced thermal resistivity (over lifetime)*
- *Assembly costs using The Max Clip System™ are lower than with conventional hardware such as screws/nuts*

The Max Clip System™ provides ideal product lifetime contact to the center of the device package resulting in even force across the interface material. Max Clips maintain a constant assembly force even when interface material deteriorates over time. With conventional nuts, bolts and rivets mounting force is set at the time of assembly and can lessen over the product's service life with changes in interface material thickness. Nuts and bolts also impart force at one end of the package creating uneven pressure over the length of the device, actually creating thermal inefficiency. See Figure 1.

Figure 1

Poor Contact

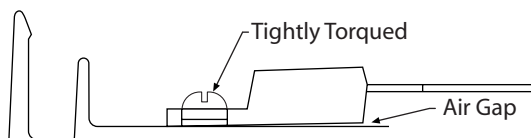

Maximum Contact

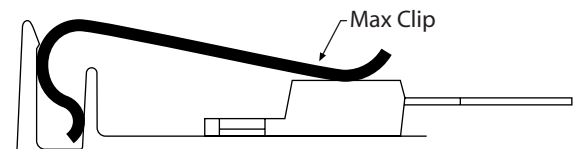

Part Number	Page	Weight kg/m	Weight lb/ft	Width mm (in)	Height mm (in)	Perimeter mm (in)	θn	θf	Type
78010	7	2.48	1.663	34.00 (1.338)	75.00 (2.953)	948.99 (37.362)	1.45	0.39	1
78015	7	1.38	0.925	27.00 (1.063)	50.02 (1.969)	499.99 (19.685)	2.46	0.65	1
78020	14	1.23	0.825	30.00 (1.181)	47.20 (1.850)	372.99 (14.685)	3.02	0.84	2
78025	12	0.99	0.664	39.00 (1.535)	31.48 (1.239)	310.01 (12.205)	3.10	1.02	1
78030	20	3.42	2.293	73.54 (2.895)	60.00 (2.362)	1002.00 (39.449)	1.10	0.36	5
78035	8	2.53	1.697	74.50 (2.933)	40.01 (1.575)	808.99 (31.850)	1.23	0.42	1
78040	14	4.64	3.111	102.00 (4.016)	71.20 (2.803)	1410.00 (55.512)	0.81	0.28	2
78045	8	1.59	1.066	40.00 (1.575)	40.00 (1.575)	475.99 (18.740)	2.12	0.64	1
78050	21	3.47	2.327	82.00 (3.228)	50.00 (1.968)	1161.62 (45.733)	0.63	0.25	6
78060	9	1.18	0.791	30.00 (1.181)	45.01 (1.772)	424.99 (16.732)	2.33	0.76	1
78070	13	2.57	1.723	40.00 (1.575)	75.00 (2.953)	783.00 (30.827)	1.55	0.41	2
78075	9	1.64	1.100	38.00 (1.496)	54.00 (2.126)	581.99 (22.913)	1.71	0.57	1
78080	7	1.74	1.167	27.00 (1.063)	60.00 (2.362)	604.01 (23.780)	2.27	0.55	1
78085	16	1.32	0.885	28.70 (1.230)	41.00 (1.614)	142.01 (5.591)	-	-	4
78090	16	0.84	0.563	17.00 (0.669)	37.28 (1.468)	143.00 (5.630)	-	-	4
78095	18	1.89	1.267	29.00 (1.142)	36.80 (1.449)	140.00 (5.512)	-	-	4
78105	20	6.10	4.090	206.00 (8.110)	90.00 (3.543)	1526.99 (60.118)	0.55	0.27	5
78110	20	5.13	3.440	155.00 (6.102)	85.00 (3.346)	1291.99 (50.866)	0.70	0.25	5
78185	18	2.14	1.435	40.00 (1.575)	57.00 (2.244)	246.98 (9.724)	-	-	4
78190	10	2.37	1.589	58.00 (2.283)	66.50 (2.618)	648.00 (25.512)	1.25	0.50	1
78195	11	1.10	0.738	34.00 (1.338)	36.60 (1.441)	313.99 (12.362)	2.70	0.93	1
78200	18	0.89	0.597	25.00 (0.984)	35.98 (1.416)	181.00 (7.126)	-	-	4
78205	13	1.57	1.053	30.00 (1.181)	57.00 (2.244)	437.99 (17.244)	2.42	0.75	2
78215	8	1.32	0.885	61.21 (2.410)	28.00 (1.102)	386.99 (15.236)	2.50	0.85	1
78220	13	1.66	1.113	30.00 (1.181)	60.00 (2.362)	488.01 (19.213)	2.49	0.74	2
78225	17	1.75	1.173	23.00 (0.905)	45.00 (1.772)	178.00 (7.008)	-	-	4
78230	18	1.39	0.932	28.00 (1.102)	45.00 (1.772)	211.98 (8.346)	-	-	4
78245	7	1.67	1.120	27.00 (1.063)	60.00 (2.362)	596.01 (23.465)	2.29	0.56	1
78250	14	2.15	1.442	60.00 (2.362)	56.00 (2.205)	632.99 (24.921)	1.42	0.52	2
78255	17	0.68	0.456	27.00 (1.063)	27.00 (1.063)	154.00 (6.063)	3.43	1.59	4
78260	19	0.12	0.080	10.50 (0.413)	11.50 (0.453)	59.99 (2.362)	-	-	3
78265	12	0.48	0.322	22.00 (0.866)	28.50 (1.122)	199.99 (7.874)	4.12	1.68	1
78270	18	0.95	0.637	27.00 (1.063)	29.50 (1.161)	156.99 (6.181)	3.43	1.59	4
78275	12	1.78	1.194	31.75 (1.250)	58.70 (2.311)	483.00 (19.016)	2.35	0.67	1
78280	18	0.75	0.503	22.98 (0.905)	38.00 (1.496)	165.98 (6.535)	3.11	1.50	4
78285	10	2.41	1.616	34.00 (1.338)	75.00 (2.953)	908.98 (35.787)	1.47	0.40	1
78290	21	9.64	6.464	240.80 (9.480)	77.00 (3.031)	1362.43 (53.639)	-	-	6
78295	11	2.18	1.462	35.00 (1.378)	60.00 (2.362)	688.00 (27.087)	1.67	0.47	1
78300	21	4.51	3.024	165.00 (6.496)	62.00 (2.441)	499.82 (19.678)	-	-	6
78305	21	1.62	1.086	120.76 (4.754)	-	659.10 (25.949)	-	-	6
78310	21	1.50	1.006	-	-	628.01 (24.725)	-	-	6
78315	9	3.14	2.106	48.00 (1.890)	80.00 (3.150)	1010.00 (39.764)	1.06	0.34	1
78335	19	0.31	0.208	30.10 (1.185)	12.50 (0.492)	138.98 (5.472)	6.34	2.38	3
78345	15	2.21	1.482	68.00 (2.677)	39.00 (1.535)	670.00 (26.378)	1.64	0.49	2
78350	9	3.45	2.313	49.50 (1.949)	85.50 (3.366)	1153.00 (45.394)	0.93	0.29	1
78355	12	1.15	0.771	32.30 (1.272)	49.00 (1.929)	456.99 (17.992)	2.34	0.76	1
78360	15	3.29	2.206	108.00 (4.252)	39.00 (1.535)	1054.98 (41.535)	1.18	0.41	2
78370	21	0.55	0.372	29.97 (1.180)	29.21 (1.150)	183.28 (7.216)	-	-	6
78375	10	1.49	0.999	54.50 (2.146)	38.60 (1.520)	445.00 (17.520)	1.82	0.78	1
78380	21	16.17	10.843	241.48 (9.507)	140.00 (5.512)	3230.29 (127.177)	-	-	6
78385	21	4.27	2.863	240.00 (9.449)	60.00 (2.362)	914.19 (35.992)	-	-	6
78390	20	6.02	4.037	179.98 (7.086)	51.00 (2.008)	1737.00 (68.386)	0.44	0.19	5

**Notes:**

θn: Thermal resistance—Natural convection. Length = 150 mm  
θf: Thermal resistance—Forced convection. Air Speed Inlet Tunnel = 2 m/s  
Black anodized or unfinished  
Ambient T = 25 °C  
Heat sink T = 100 °C

**Type definitions:**

1= Single Mounting Surface Style  
2= Dual Mounting Surface Style  
3= Single Mounting Surface with Flatback Style  
4= Max Heat Connector Style  
5= U-Channel/Multiple Screw Boss Style  
6= Potential Max Profiles

# Max Extrusion Index

MAX EXTRUSION INDEX

Part Number	Page	Weight kg/m	Weight lb/ft	Width mm (in)	Height mm (in)	Perimeter mm (in)	θn	θf	Type
78405	11	1.36	0.912	49.00 (1.929)	40.00 (1.575)	554.99 (21.850)	1.32	0.56	1
81400	20	5.51	3.695	124.16 (3.160)	80.26 (3.160)	1065.50 (41.949)	0.98	0.38	5
82005	15	2.60	1.743	71.12 (2.800)	38.81 (1.528)	610.69 (24.043)	-	-	2
82870	10	3.09	2.072	35.00 (1.378)	90.10 (3.547)	1062.99 (41.850)	1.35	0.32	1
82875	16	0.95	0.637	23.00 (0.905)	36.90 (1.453)	127.99 (5.039)	-	-	4
82880	17	1.72	1.153	30.00 (1.181)	49.70 (1.957)	226.99 (8.937)	-	-	4
82885	16	0.85	0.570	21.40 (0.842)	34.00 (1.338)	121.99 (4.803)	-	-	4
82890	16	1.40	0.939	15.00 (0.590)	56.60 (2.228)	159.00 (6.260)	-	-	4
82895	19	1.08	0.724	22.00 (0.866)	48.00 (1.890)	248.99 (9.803)	3.42	1.57	3
82900	16	1.18	0.791	28.00 (1.102)	35.00 (1.378)	170.99 (6.732)	-	-	4
82905	14	2.02	1.355	49.50 (1.949)	50.00 (1.968)	672.00 (26.457)	1.92	0.57	2
82910	8	2.45	1.643	50.00 (1.968)	69.00 (2.716)	800.98 (31.535)	1.28	0.44	1
82920	10	2.38	1.596	35.00 (1.378)	75.00 (2.953)	899.00 (35.394)	1.56	0.41	1
82925	17	1.69	1.133	38.00 (1.496)	30.00 (1.181)	180.00 (7.087)	-	-	4
82930	8	2.04	1.368	50.00 (1.968)	47.00 (1.850)	532.99 (20.984)	1.71	0.58	1
82935	7	2.51	1.683	34.00 (1.338)	75.00 (2.953)	878.00 (34.567)	-	-	1
82940	11	1.14	0.764	55.00 (2.165)	43.00 (1.693)	280.00 (11.024)	1.96	1.00	1
82945	17	1.89	1.267	27.00 (1.063)	38.00 (1.496)	146.98 (5.787)	-	-	4
82950	8	5.52	3.701	45.00 (1.772)	120.00 (4.724)	1162.99 (45.787)	-	-	1
82955	13	1.41	0.945	30.00 (1.181)	49.80 (1.961)	378.00 (14.882)	2.99	0.83	2
82960	20	2.75	1.844	73.50 (2.894)	50.00 (1.968)	721.00 (28.386)	1.30	0.46	5
82965	19	0.90	0.604	15.00 (0.590)	54.00 (2.126)	264.00 (10.394)	3.43	1.12	3
82970	19	0.41	0.275	33.00 (1.300)	21.00 (0.827)	186.99 (7.362)	4.38	2.10	3
82975	9	0.74	0.496	25.00 (0.984)	37.50 (1.476)	-	3.31	1.55	1
82980	17	0.81	0.543	27.00 (1.063)	27.00 (1.063)	135.00 (5.315)	-	-	4
82985	14	2.24	1.502	55.00 (2.165)	65.40 (2.575)	-	1.52	0.62	2
82990	9	1.18	0.791	35.00 (1.378)	37.50 (1.476)	-	2.49	0.95	1
83000	11	1.45	0.972	38.00 (1.496)	54.00 (2.126)	381.00 (15.000)	1.83	0.77	1
83005	7	1.73	1.160	27.00 (1.063)	60.00 (2.362)	581.99 (22.913)	2.30	0.59	1
83010	14	4.36	2.924	50.00 (1.968)	73.00 (2.874)	-	1.17	0.35	2
83015	11	1.49	0.999	46.90 (1.846)	51.60 (2.031)	-	1.73	0.69	1
83020	12	3.57	2.394	75.00 (2.953)	50.00 (1.968)	-	-	-	1
OSA24	21	-	-	-	-	-	-	-	6
OSA55	21	-	-	-	-	-	-	-	6
OSA61	21	-	-	-	-	-	-	-	6
OS567	21	-	-	-	-	-	-	-	6
OSA69	21	-	-	-	-	-	-	-	6
OSA74	21	-	-	-	-	-	-	-	6
OSA79	22	-	-	-	-	-	-	-	6
OSA80	22	-	-	-	-	-	-	-	6
OSY94	22	-	-	-	-	-	-	-	6
BS014	22	-	-	-	-	-	-	-	6
BS034	22	-	-	-	-	-	-	-	6
BS060	22	-	-	-	-	-	-	-	6
BS070	22	-	-	-	-	-	-	-	6
BS093	22	-	-	-	-	-	-	-	6
BS094	22	-	-	-	-	-	-	-	6
BS105	22	-	-	-	-	-	-	-	6
BS121	22	-	-	-	-	-	-	-	6
BS138	22	-	-	-	-	-	-	-	6
BS202	22	-	-	-	-	-	-	-	6

**Notes:**

θn: Thermal resistance—Natural convection. Length = 150 mm  
 θf: Thermal resistance—Forced convection. Air speed inlet Tunnel = 2 m/s  
 Black anodized or unfinished  
 Ambient T = 25 °C  
 Heat sink T = 100 °C

**Type definitions:**

1= Single Mounting Surface Style  
 2= Dual Mounting Surface Style  
 3= Single Mounting Surface with Flatback Style  
 4= Max Heat Connector Style  
 5= U-Channel/Multiple Screw Boss Style  
 6= Potential Max Profiles

The Single Mounting Surface style provides a flat component mounting surface on one side of the profile. The back side of the extrusion is covered with fins creating additional surface area to aid in cooling. The component retaining clip interlocks between the first and second fin above the flat component mounting surface.

## 78015

kg/m: 1.38 •  $\theta_n = 2.46$  °C/W •  $\theta_f = 0.65$  °C/W

- One slot for vertical mounting to board

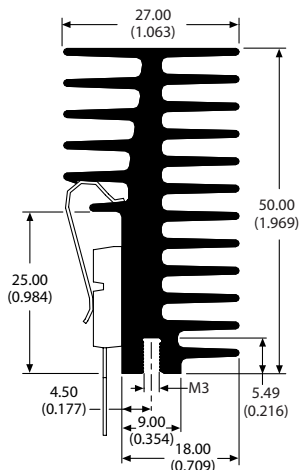

## 78245

kg/m: 1.66 •  $\theta_n = 2.29$  °C/W •  $\theta_f = 0.56$  °C/W

- One slot for vertical mounting to board

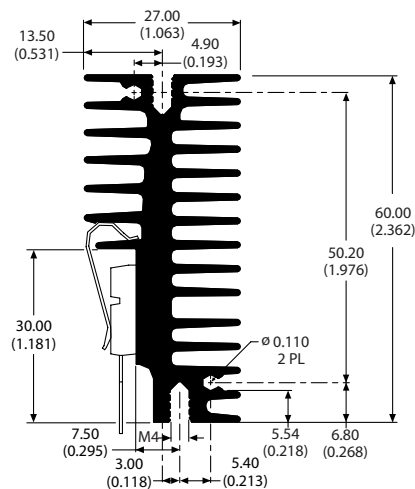

## 78080

kg/m: 1.74 •  $\theta_n = 2.27$  °C/W •  $\theta_f = 0.55$  °C/W

- One slot for vertical mounting to board

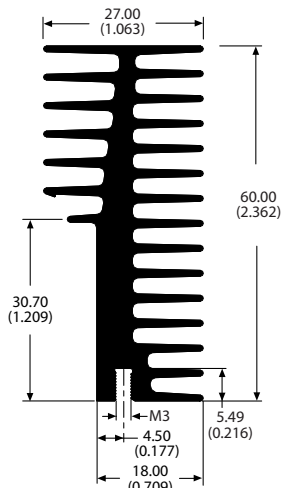

## 78010

kg/m: 2.48 •  $\theta_n = 1.45$  °C/W •  $\theta_f = 0.39$  °C/W

- One slot for vertical mounting to board

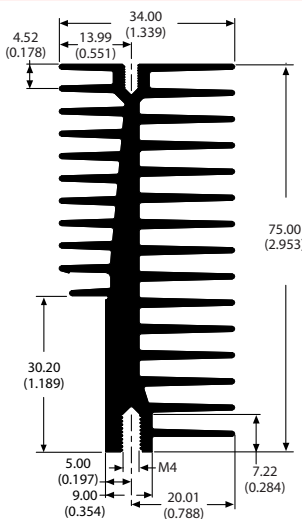

## 83005

kg/m: 1.73 •  $\theta_n = 2.30$  °C/W •  $\theta_f = 0.59$  °C/W

- One slot for vertical mounting to board

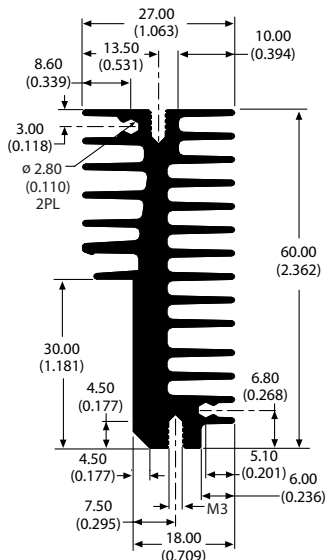

## 82935

kg/m: 2.51 •  $\theta_n = 1.45$  °C/W •  $\theta_f = 0.39$  °C/W

- One slot for vertical mounting to board

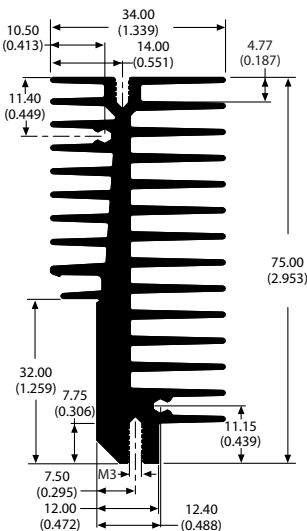



**82950**

kg/m: 5.52

- One screw boss for vertical mounting to board

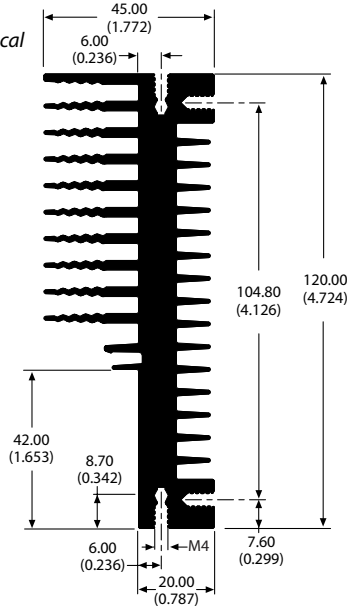

**82910**

kg/m: 2.45 •  $\theta_n = 1.28$  °C/W •  $\theta_f = 0.44$  °C/W

- One screw boss for vertical mounting to board

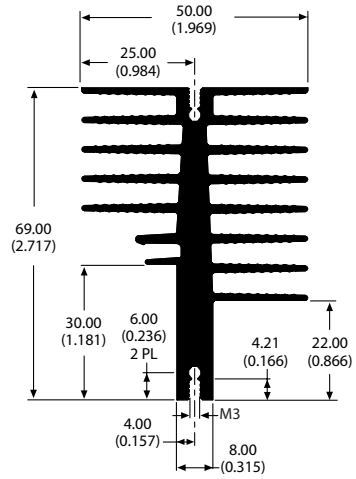

**82930**

kg/m: 2.04 •  $\theta_n = 1.71$  °C/W •  $\theta_f = 0.58$  °C/W

- One slot for vertical mounting to board

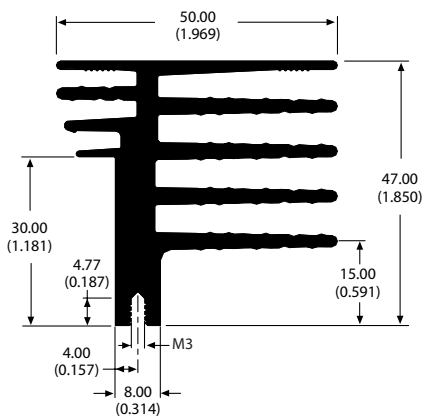

**78045**

kg/m: 1.59 •  $\theta_n = 2.12$  °C/W •  $\theta_f = 0.64$  °C/W

- One slot for vertical mounting to board

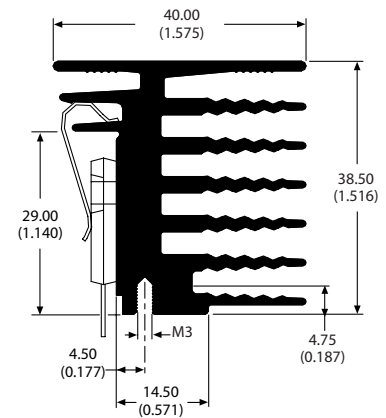

**78035**

kg/m: 2.53 •  $\theta_n = 1.23$  °C/W •  $\theta_f = 0.42$  °C/W

- Two slots for vertical mounting to board

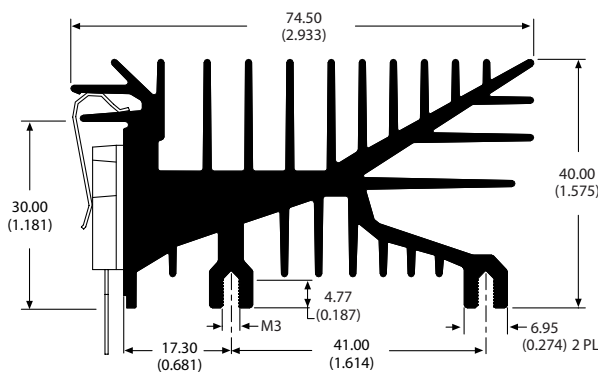

**78215**

kg/m: 1.32 •  $\theta_n = 2.50$  °C/W •  $\theta_f = 0.85$  °C/W

- One screw boss for vertical mounting to board

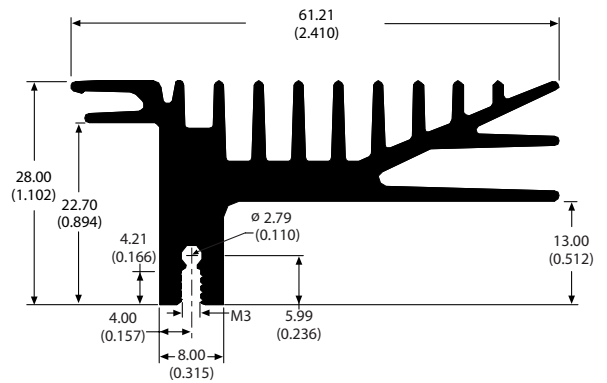

**78075**

kg/m: 1.64 •  $\theta_n = 1.71$  °C/W •  $\theta_f = 0.57$  °C/W

- One slot for vertical mounting to board

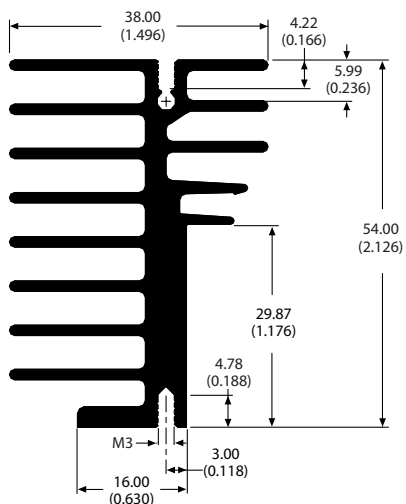

**78060**

kg/m: 1.18 •  $\theta_n = 2.33$  °C/W •  $\theta_f = 0.76$  °C/W

- One slot for vertical mounting to board

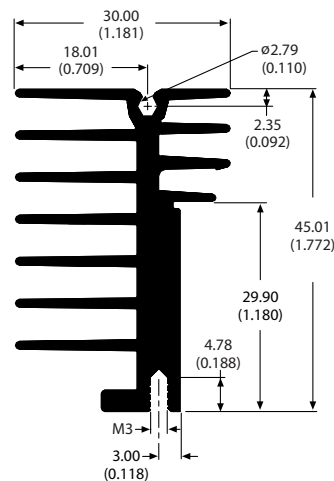

**78350**

kg/m: 3.45 •  $\theta_n = 0.93$  °C/W •  $\theta_f = 0.29$  °C/W

- One screw boss for vertical mounting to board

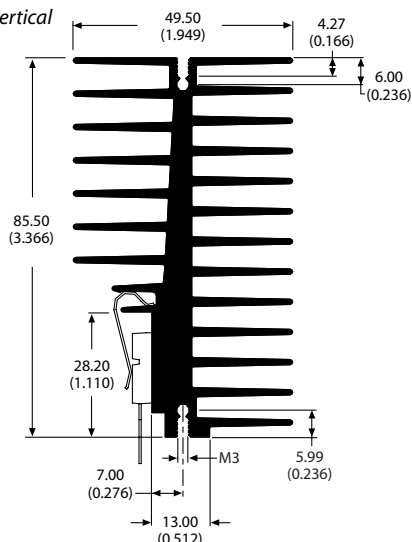

**78315**

kg/m: 3.14 •  $\theta_n = 1.06$  °C/W •  $\theta_f = 0.34$  °C/W

- One slot for vertical mounting to board

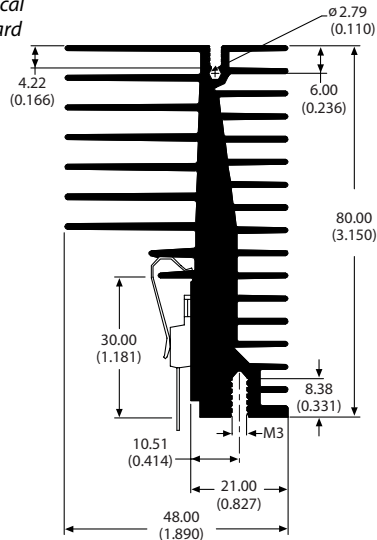

**82990**

kg/m: 1.18 •  $\theta_n = 2.49$  °C/W •  $\theta_f = 0.95$  °C/W

- Two slots for vertical mounting to board

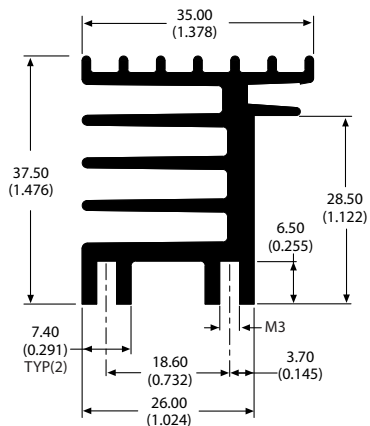

**82975**

kg/m: 0.74 •  $\theta_n = 3.31$  °C/W •  $\theta_f = 1.55$  °C/W

- Two slots for vertical mounting to board

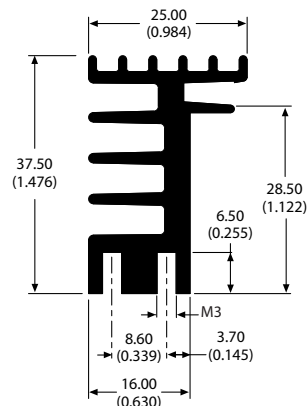

**78375** kg/m: 1.49 •  $\theta_n = 1.82$  °C/W •  $\theta_f = 0.78$  °C/W

- One screw boss for vertical mounting to board

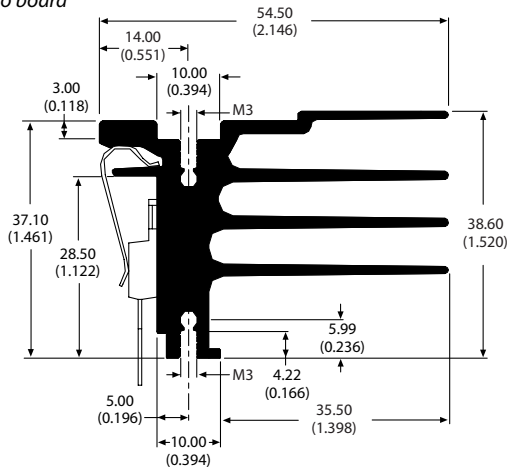

**78190** kg/m: 2.37 •  $\theta_n = 1.25$  °C/W •  $\theta_f = 0.50$  °C/W

- One screw boss for vertical mounting to board

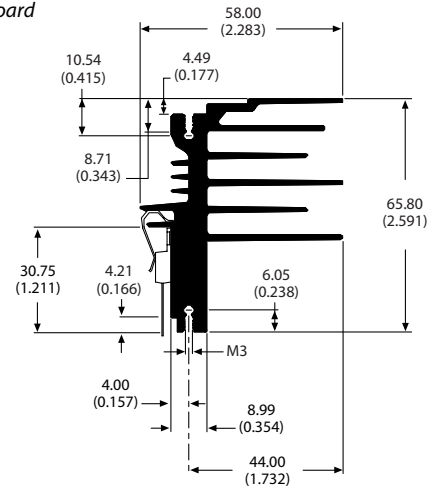

**78285** kg/m: 2.41 •  $\theta_n = 1.47$  °C/W •  $\theta_f = 0.40$  °C/W

- One slot for vertical mounting to board

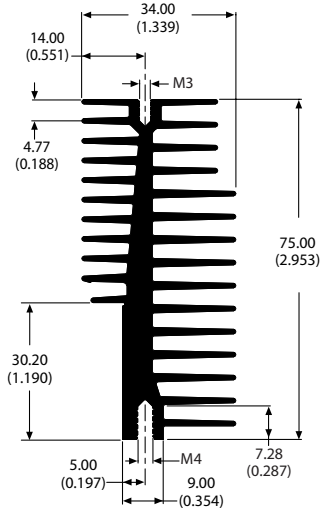

**82870** kg/m: 3.09 •  $\theta_n = 1.35$  °C/W •  $\theta_f = 0.32$  °C/W

- One slot for vertical mounting to board

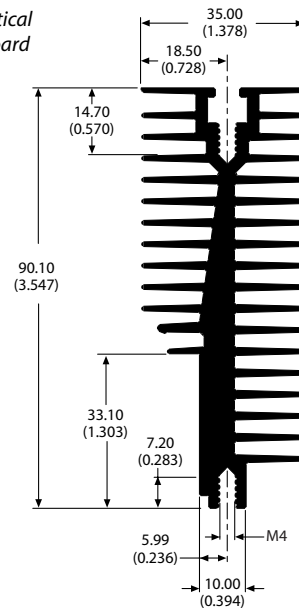

**82920** kg/m: 2.38 •  $\theta_n = 1.56$  °C/W •  $\theta_f = 0.41$  °C/W

- One slot for vertical mounting to board

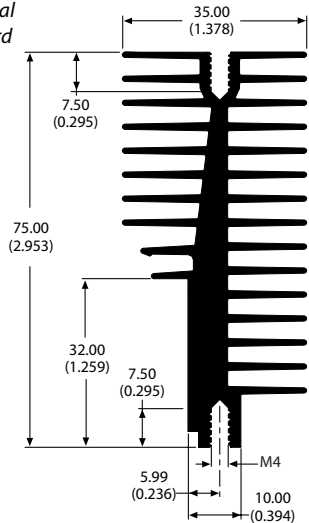

**78295**

kg/m: 2.18 •  $\theta_n = 1.67$  °C/W •  $\theta_f = 0.47$  °C/W

- One slot for vertical mounting to board

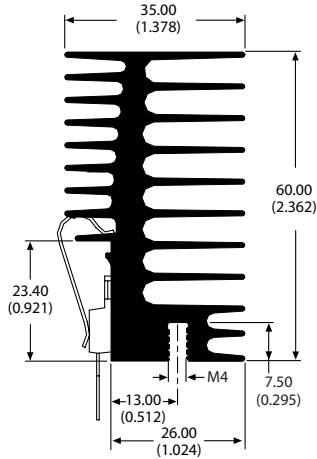

**83000**

kg/m: 1.45 •  $\theta_n = 1.83$  °C/W •  $\theta_f = 0.77$  °C/W

- Two screw bosses for vertical mounting to board

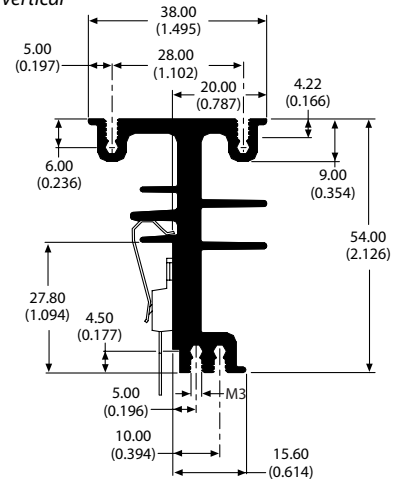

**82940**

kg/m: 1.14 •  $\theta_n = 1.96$  °C/W •  $\theta_f = 1.00$  °C/W

- One screw boss for vertical mounting to board

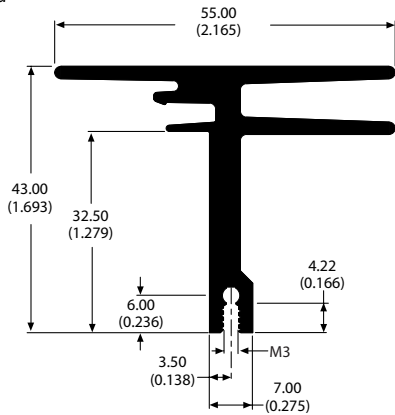

**78405**

kg/m: 1.36 •  $\theta_n = 1.32$  °C/W •  $\theta_f = 0.56$  °C/W

- One slot for vertical mounting to board

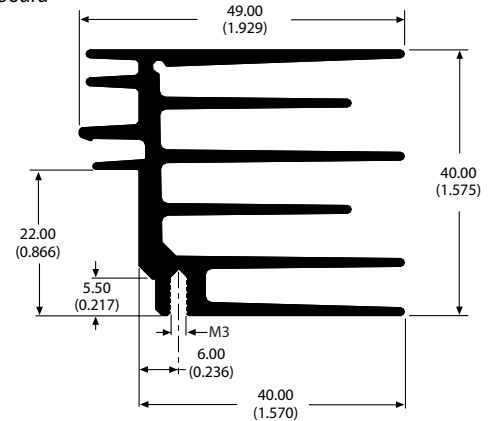

**83015**

kg/m: 1.49 •  $\theta_n = 1.73$  °C/W •  $\theta_f = 0.69$  °C/W

- One slot for vertical mounting to board

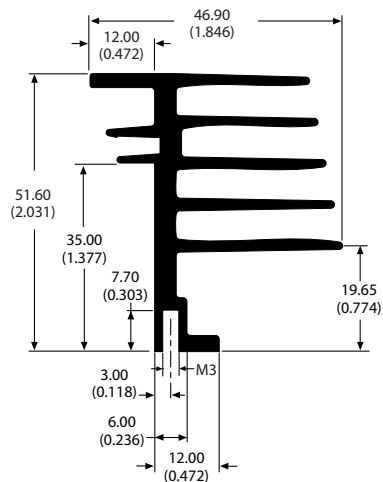

**78195**

kg/m: 1.10 •  $\theta_n = 2.70$  °C/W •  $\theta_f = 0.93$  °C/W

- One screw boss for vertical mounting to board

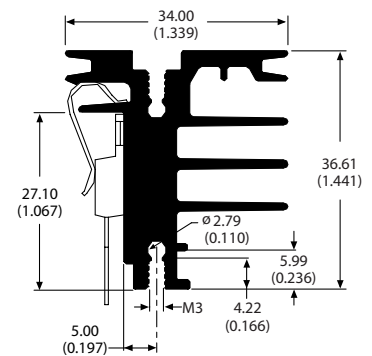

**78275**

kg/m: 1.78 •  $\theta_n = 2.35$  °C/W •  $\theta_f = 0.67$  °C/W

- One screw boss for vertical mounting to board

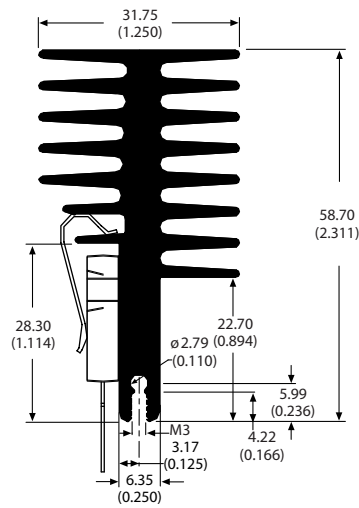

**78355**

kg/m: 1.15 •  $\theta_n = 2.34$  °C/W •  $\theta_f = 0.76$  °C/W

- One screw boss for vertical mounting to board

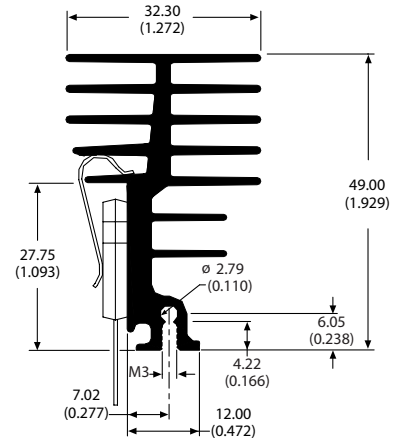

**78265**

kg/m: 0.48 •  $\theta_n = 4.12$  °C/W •  $\theta_f = 1.68$  °C/W

- One slot for vertical mounting to board

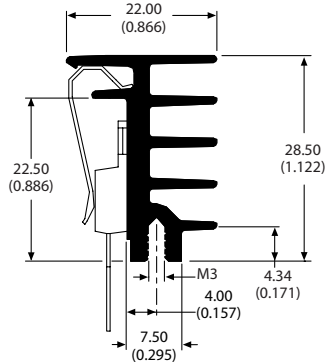

**78025**

kg/m: 0.99 •  $\theta_n = 3.10$  °C/W •  $\theta_f = 1.02$  °C/W

- One slot for vertical mounting to board

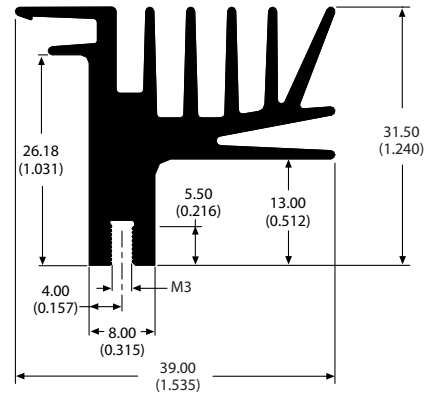

**83020**

kg/m: 3.57

- Two slots for vertical mounting to board

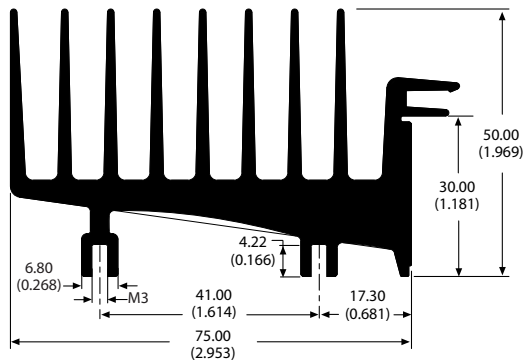

The Dual Mounting Surface style provides a flat component mounting surface on two sides of the profile. Some profiles allow back to back mounting of components on the circuit board permitting the sharing of a centrally mounted heat sink. Other profiles create a bridge configuration allowing components to be attached to each leg with a raised center section to clear adjacent components or create a tunnel for airflow. The clip used to retain the component interlocks between the first and second fin above the flat component mounting surface.

## 78205

kg/m: 1.57 •  $\theta_n = 2.42 \text{ }^\circ\text{C/W}$  •  $\theta_f = 0.75 \text{ }^\circ\text{C/W}$

- One slot for vertical mounting to board

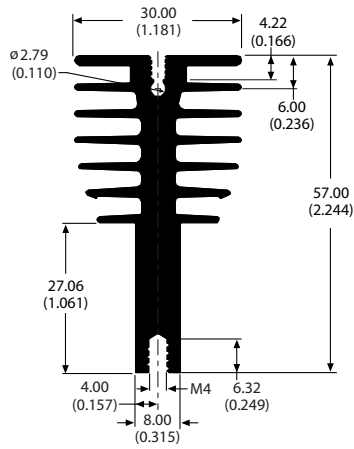

## 78070

kg/m: 2.57 •  $\theta_n = 1.55 \text{ }^\circ\text{C/W}$  •  $\theta_f = 0.41 \text{ }^\circ\text{C/W}$

- One slot for vertical mounting to board

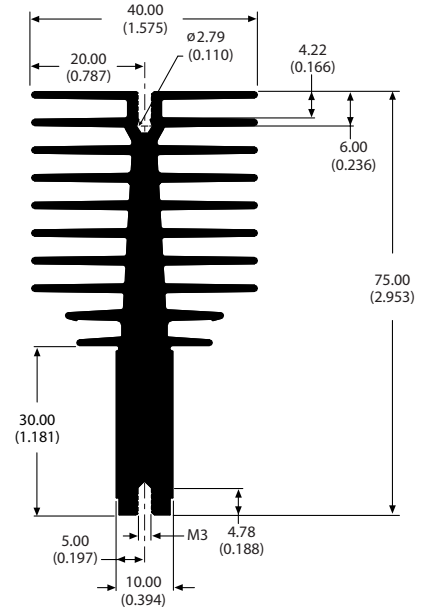

## 78220

kg/m: 1.66 •  $\theta_n = 2.49 \text{ }^\circ\text{C/W}$  •  $\theta_f = 0.74 \text{ }^\circ\text{C/W}$

- One slot for vertical mounting to board

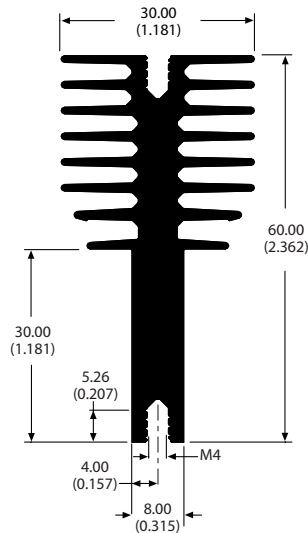

## 82955

kg/m: 1.41 •  $\theta_n = 2.99 \text{ }^\circ\text{C/W}$  •  $\theta_f = 0.83 \text{ }^\circ\text{C/W}$

- One slot for vertical mounting to board

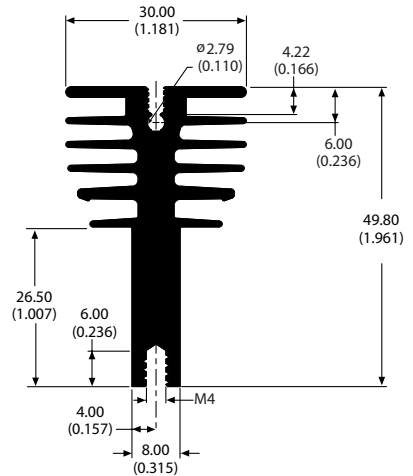

**78040** kg/m: 4.64 •  $\theta_n = 0.81$  °C/W •  $\theta_f = 0.28$  °C/W

- Two slots for vertical mounting to board

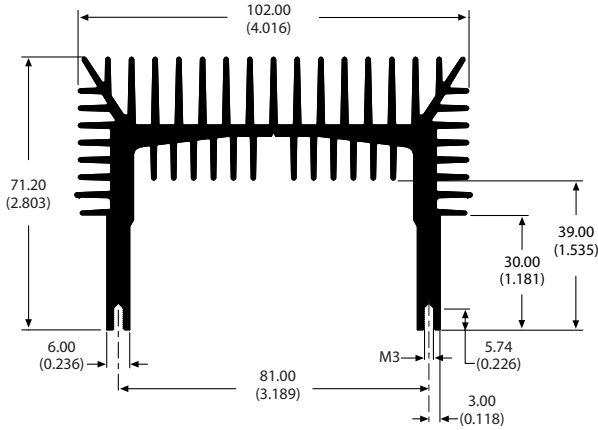

**83010** kg/m: 4.36 •  $\theta_n = 1.17$  °C/W •  $\theta_f = 0.35$  °C/W

- Two slots for vertical mounting to board

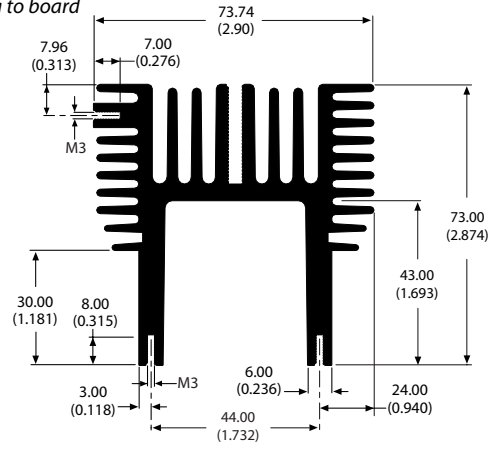

**78020** kg/m: 1.23 •  $\theta_n = 3.02$  °C/W •  $\theta_f = 0.84$  °C/W

- One slot for vertical mounting to board

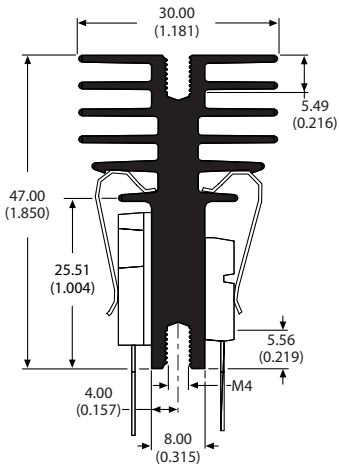

**82985** kg/m: 2.24 •  $\theta_n = 1.52$  °C/W •  $\theta_f = 0.62$  °C/W

- One slot for vertical mounting to board

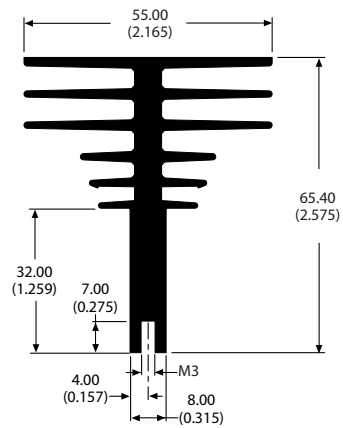

**78250** kg/m: 2.15 •  $\theta_n = 1.42$  °C/W •  $\theta_f = 0.52$  °C/W

- One slot for vertical mounting to board

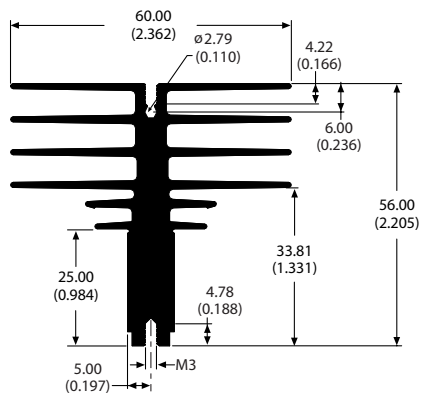

**82905** kg/m: 2.02 •  $\theta_n = 1.92$  °C/W •  $\theta_f = 0.57$  °C/W

- Two screw bosses for vertical mounting to board

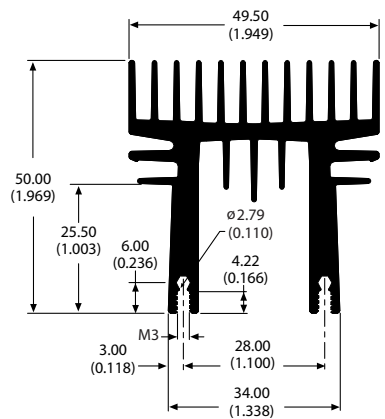

**78345** kg/m: 2.21 •  $\theta_n = 1.64 \text{ }^\circ\text{C/W}$  •  $\theta_f = 0.49 \text{ }^\circ\text{C/W}$

- Two screw bosses for vertical mounting to board

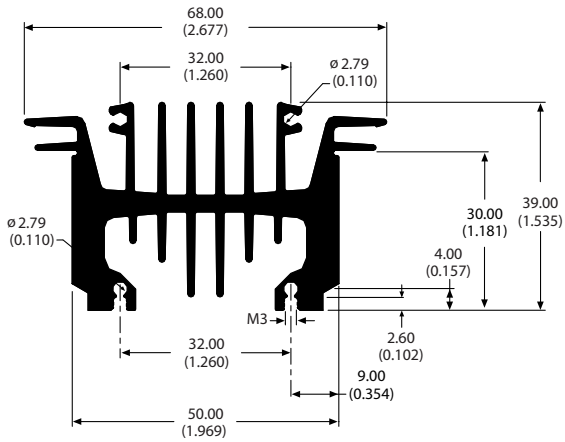

**78360** kg/m: 3.29 •  $\theta_n = 1.18 \text{ }^\circ\text{C/W}$  •  $\theta_f = 0.41 \text{ }^\circ\text{C/W}$

- Secondary operation needed for mounting to board

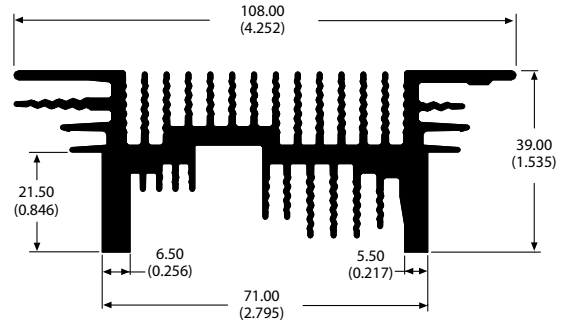

**82005** kg/m: 2.60

- Two slots for vertical mounting to board

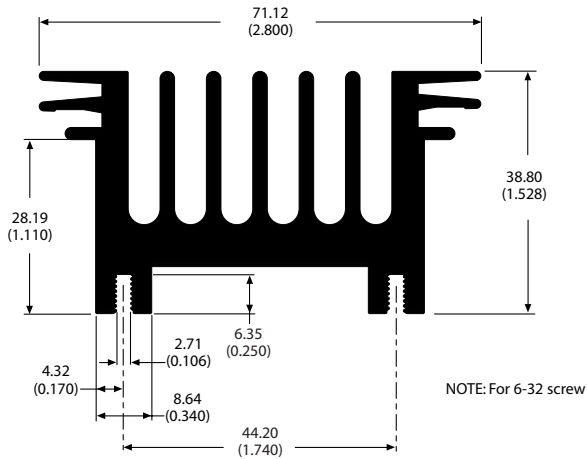



# The Max Clip System™ Max Heat Connector

The Max Heat Connector styles include single and dual component mounting surface profiles. Max Heat Connector profiles are designed to be fastened to conventional extruded heat sink or chassis surfaces providing a thermal conduction path for heat dissipation. Application examples are shown on page 29. Like other Max Extrusion Profiles, the clip used to retain the component interlocks between the first and second fin above the flat component mounting surface.

**78090**

kg/m: 0.84

- One slot for vertical mounting to board

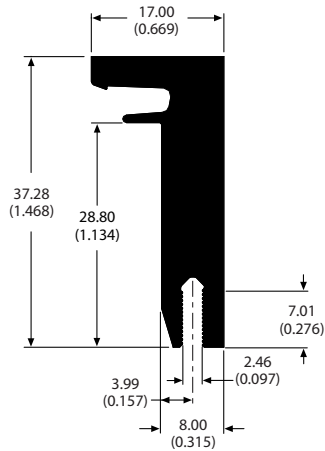

**82885**

kg/m: 0.85

- Secondary operation needed for mounting to board

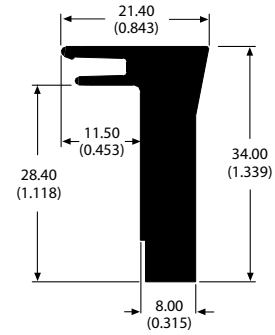

**82890**

kg/m: 1.40

- Secondary operation needed for mounting to board

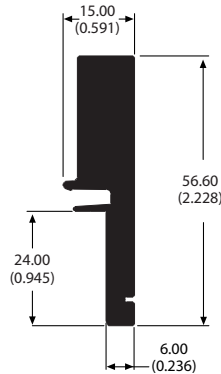

**78085**

kg/m: 1.32

- Secondary operation needed for mounting to board

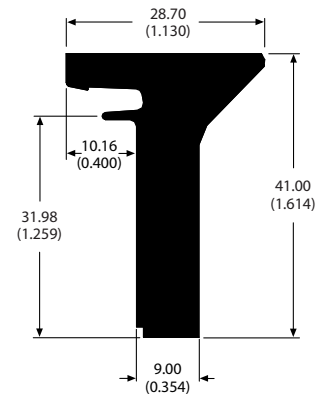

**82875**

kg/m: 0.95

- Secondary operation needed for mounting to board

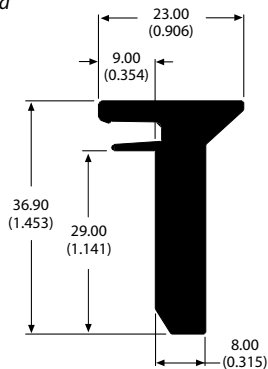

**82900**

kg/m: 1.18

- Secondary operation needed for mounting to board

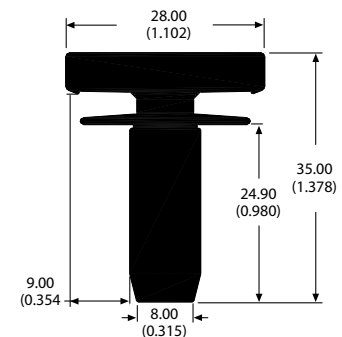

**82925**

kg/m: 1.69

- One slot for vertical mounting to board

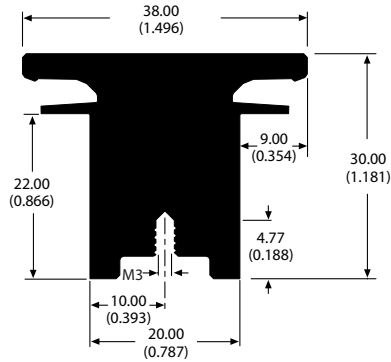

**78255**

kg/m: 0.69 •  $\theta_n=3.43$  °C/W •  $\theta_f=1.59$  °C/W

- One slot for vertical mounting to board

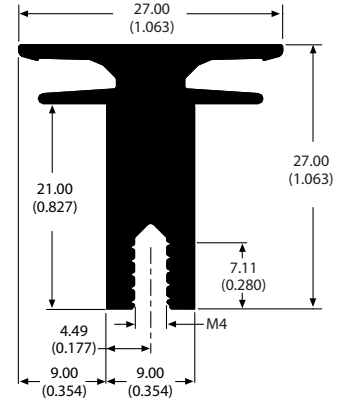

**82980**

kg/m: 0.81

- Secondary operation needed for mounting to board

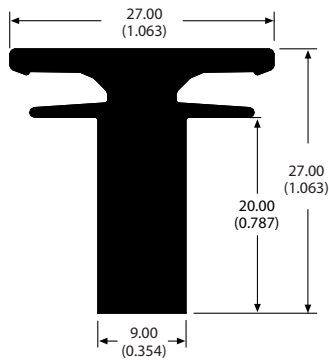

**82945**

kg/m: 1.89

- Secondary operation needed for mounting to board

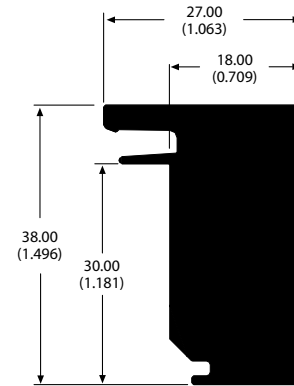

**82880**

kg/m: 1.72

- One screw boss for vertical mounting to board

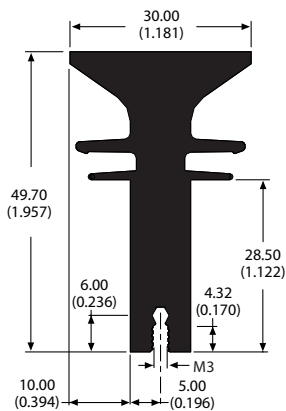

**78225**

kg/m: 1.75

- One slot for vertical mounting to board

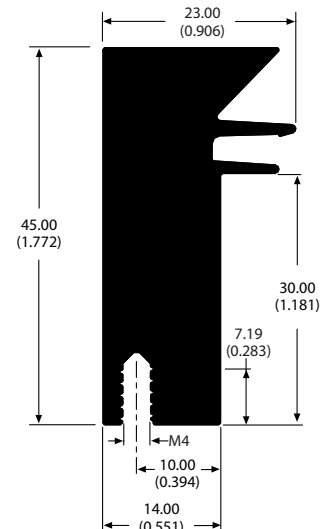

**78095** kg/m: 1.89

- Secondary operation needed for mounting to board

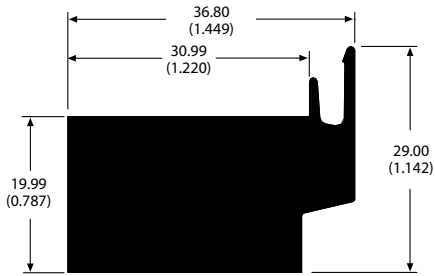

**78185** kg/m: 2.14

- Secondary operation needed for mounting to board

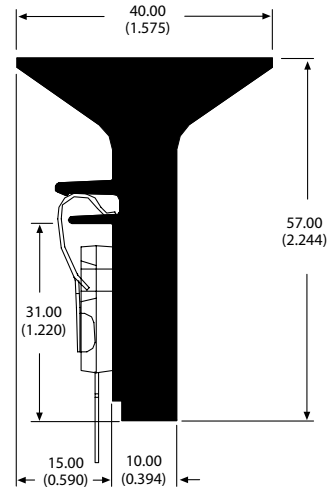

**78200** kg/m: 0.89

- One screw boss for vertical mounting to board

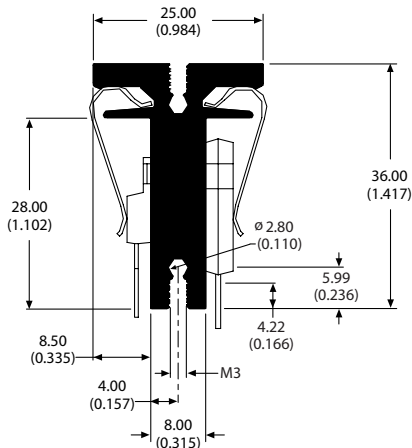

**78230** kg/m: 1.39

- One slot for vertical mounting to board

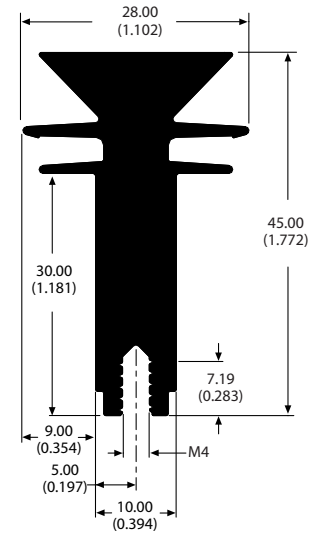

**78280** kg/m: 0.75 •  $\theta_n = 3.11$  °C/W •  $\theta_f = 1.50$  °C/W

- One screw boss for vertical mounting to board

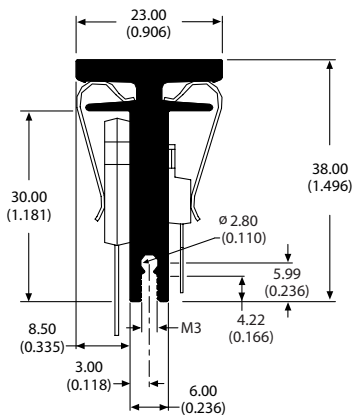

**78270** kg/m: 0.95 •  $\theta_n = 3.43$  °C/W •  $\theta_f = 1.59$  °C/W

- One screw boss for vertical mounting to board

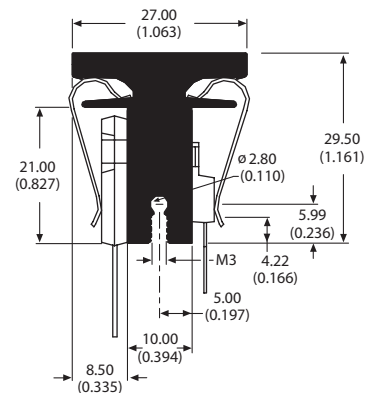

Single Mounting Surface with Flat Back styles feature profiles with one side dedicated to a single component mounting surface and cooling fins with a flat surface on the back side of the profile. This style is suitable in applications with tight space requirements or where the Max Extrusion will be mounted horizontally. The clip used to retain the component interlocks between the first and second fin above the flat component mounting surface.

**82965** kg/m: 0.90 •  $\theta_n = 3.43 \text{ }^\circ\text{C/W}$  •  $\theta_f = 1.12 \text{ }^\circ\text{C/W}$

- One screw boss for vertical mounting to board

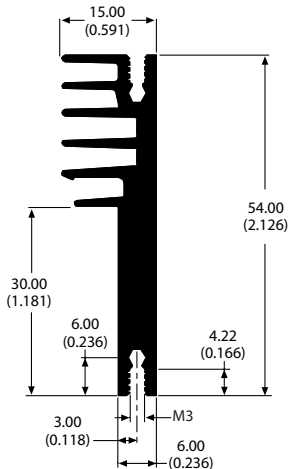

**82895** kg/m: 1.08 •  $\theta_n = 3.42 \text{ }^\circ\text{C/W}$  •  $\theta_f = 1.57 \text{ }^\circ\text{C/W}$

- One screw boss for vertical mounting to board

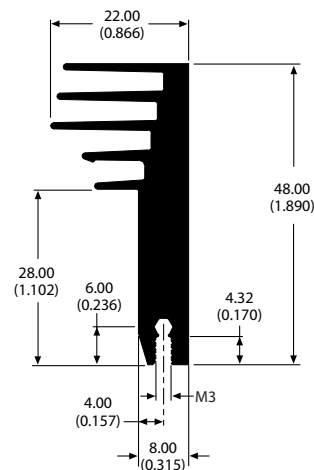

**78335** kg/m: 0.31 •  $\theta_n = 6.34 \text{ }^\circ\text{C/W}$  •  $\theta_f = 2.38 \text{ }^\circ\text{C/W}$

- Horizontally mounted

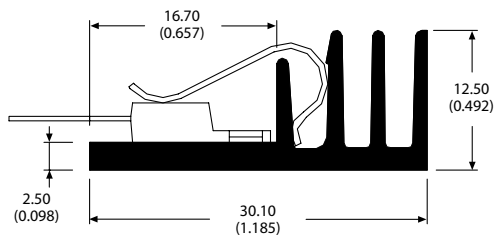

**82970** kg/m: 0.41 •  $\theta_n = 4.38 \text{ }^\circ\text{C/W}$  •  $\theta_f = 2.10 \text{ }^\circ\text{C/W}$

- Horizontally mounted

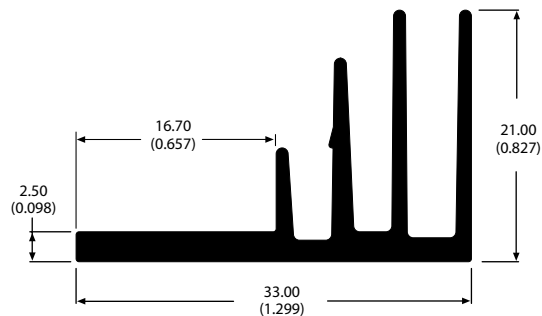

**78260** kg/m: 0.12

- Horizontally mounted

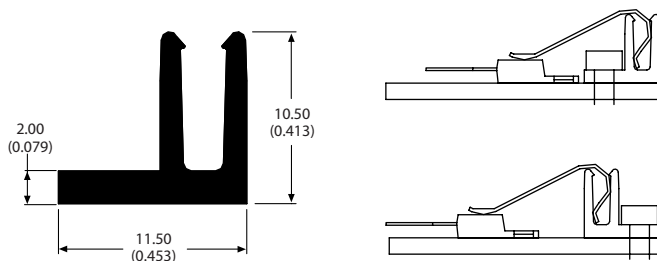

# The Max Clip System™ U-Channel/Multiple Screw Boss

The U-Channel/Multiple Screw Boss section features a combination of U-Channel style and custom Max Profiles featuring multiple (2 or more) screw bosses. The U-Channel variations can accept assembled circuit cards to form the basis of a chassis. Additional screw bosses allow attachment of side and top panels completing a chassis assembly. The incorporation of Multiple Screw Boss features into a profile provides the flexibility to mount the heat sink to the board in horizontal or vertical orientation using a standard screw.

**78105** kg/m: 6.10 •  $\theta_n = 0.55$  °C/W •  $\theta_f = 0.27$  °C/W

- Chassis assembly capabilities

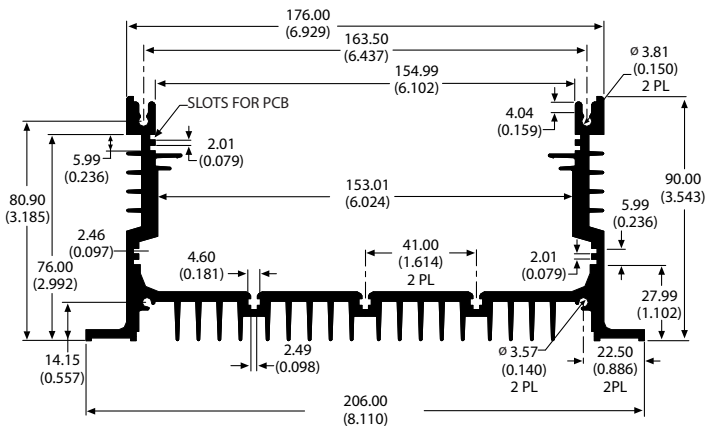

**78110** kg/m: 5.13 •  $\theta_n = 0.70$  °C/W •  $\theta_f = 0.50$  °C/W

- Chassis assembly capabilities

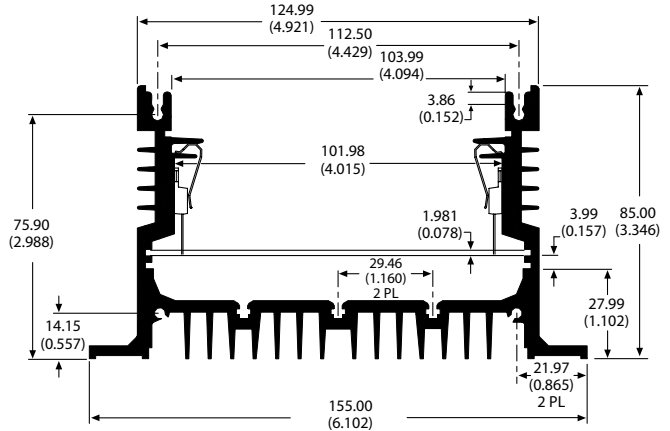

**78030** kg/m: 3.42 •  $\theta_n = 1.10$  °C/W •  $\theta_f = 0.36$  °C/W

- Four screw boss slots for vertical mounting to board

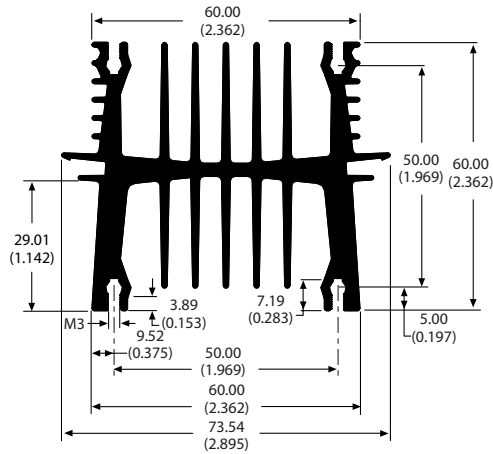

**82960** kg/m: 2.75 •  $\theta_n = 1.30$  °C/W •  $\theta_f = 0.46$  °C/W

- Two screw boss slots for vertical mounting to board

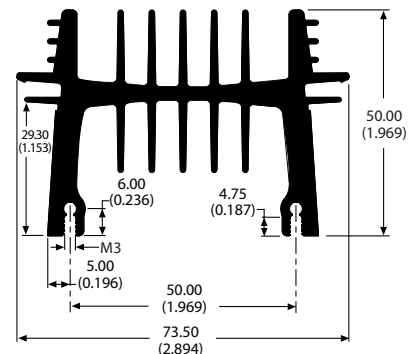

**81400** kg/m: 5.51

- Two slots for circuit board mounting

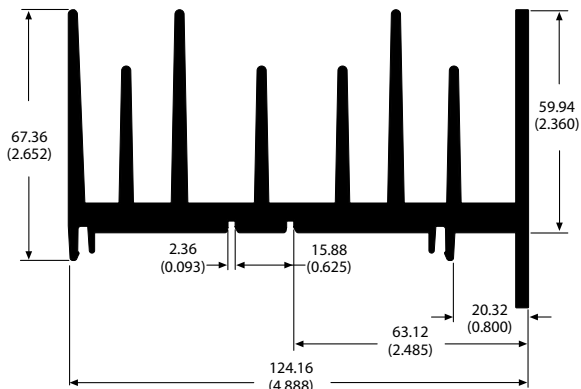

**78390** kg/m: 6.02 •  $\theta_n = 0.44$  °C/W •  $\theta_f = 0.19$  °C/W

- Five slots for horizontal mounting to board

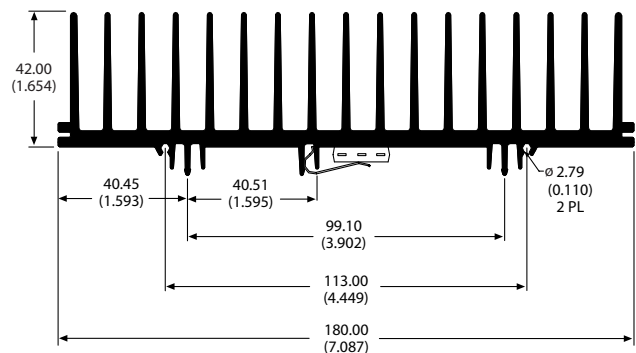

Application of The Max Clip System™ is limited only by the imagination. The following pages illustrate some examples of custom Max Extrusions. The system's flexibility allows the creation of shapes designed for specific thermal or mechanical system requirements. Please contact Aavid application engineering to discuss any of the shapes shown below or your custom application specifications.

78050

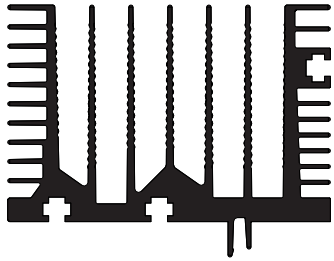

0S567

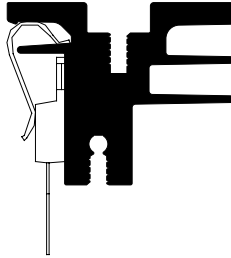

78370

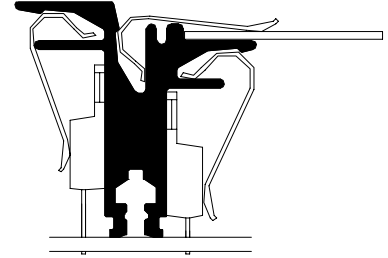

78380

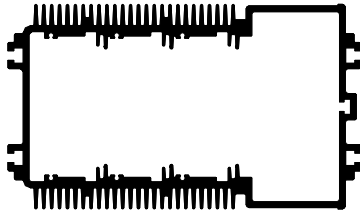

78300



78305

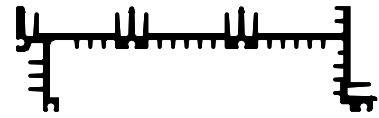

78310



0SA24



78290

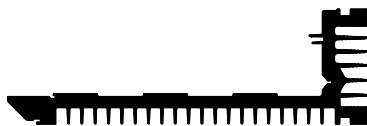

78385



0SA55



0SA61

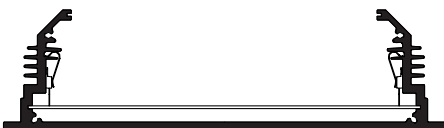

0SA69



0SA74



OSA79



OSA80

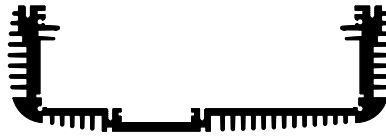

OSY94



BS014

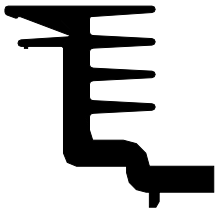

BS034

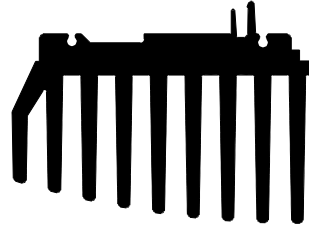

BS060



BS070

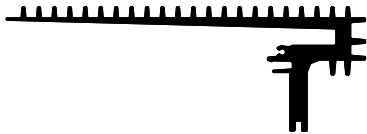

BS093

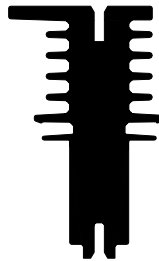

BS094

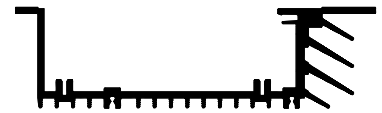

BS105



BS121



BS138

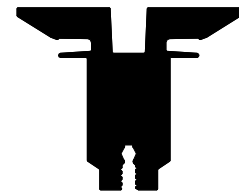

BS202



Part Number	Normal Force 20N-40N TO-220 TO-218 TO-251 TO-262 TO-273	Short Clip TO-220 TO-218 TO-251 TO-262 TO-273	Long Clip TO-220 TO-218 TO-251 TO-262 TO-273	High Force 50N + TO-220 TO-218 TO-251 TO-262 TO-273	Normal Force 30N-50N TO-247 TO-274	High Force 60N + TO-247 TO-274 TO-3P	Sensors Small Component	Special D61 TO-247J TO-274	Special Thick Isolators Solid State Relay*
78010	Max01 Max02	-	Max10 Max11	Max01-H	Max03	Max02-H Max03-H	Max12	Max04 Max15	Max23
78015	Max01 Max02	Max09	Max10	Max01-H	Max03	Max02-H Max03-H	Max12	-	Max23
78020	Max01 Max02	Max09	Max10	Max01-H	Max03	Max02-H Max03-H	Max12	Max15	Max23
78025	Max01 Max02	Max09	Max10	Max01-H	Max03	Max02-H Max03-H	Max12	Max15	Max23
78030	Max01 Max02	Max09	Max10 Max11	Max01-H	Max03	Max02-H Max03-H	Max12	Max04 Max15	Max23
78035	Max01 Max02	-	Max10 Max11	Max01-H	Max03	Max02-H Max03-H	Max12	Max04 Max15	Max23
78040	Max01 Max02	-	Max10 Max11	Max01-H	Max03	Max02-H Max03-H	Max12	Max04 Max15	Max23
78045	Max01 Max02	Max09	Max10	Max01-H	Max03	Max02-H Max03-H	Max12	Max04 Max15	Max23
78060	Max01 Max02	-	Max10 Max11	Max01-H	Max03	Max02-H Max03-H	Max12	Max04 Max15	Max23
78070	Max01 Max02	-	Max10	Max01-H	Max03	Max02-H Max03-H	Max12	Max04 Max15	Max23
78075	Max01 Max02	-	Max10 Max11	Max01-H	Max03	Max02-H Max03-H	Max12	Max04 Max15	Max23
78080	Max01 Max02	-	Max10 Max11	Max01-H	Max03	Max02-H Max03-H	Max12	Max04 Max15	Max23
78085	Max01 Max02	-	Max10 Max11	Max01-H	Max03	Max02-H Max03-H	Max12	Max04 Max15	Max23
78090	Max01 Max02	Max09	Max10 Max11	Max01-H	Max03	Max02-H Max03-H	Max12	Max04 Max15	Max23
78095	Max01 Max02	-	Max10 Max11	Max01-H	Max03	Max02-H Max03-H	Max12	Max04 Max15	Max23
78105	Max01 Max02	-	Max10 Max11	Max01-H	Max03	Max02-H Max03-H	Max12	Max04 Max15	Max23
78110	Max01 Max02	-	Max10 Max11	Max01-H	Max03	Max02-H Max03-H	Max12	Max04 Max15	Max23
78185	Max01 Max02	-	Max10 Max11	Max01-H	Max03	Max02-H Max03-H	Max12	Max04 Max15	Max23
78190	Max01 Max02	-	Max10	Max01-H	Max03	Max02-H Max03-H	Max12	Max04 Max15	Max23
78195	Max01 Max02	Max09	-	Max01-H	Max03	Max02-H Max03-H	-	Max04 Max15	Max23
78200	Max01 Max02	Max09	Max10 Max11	Max01-H	Max03	Max02-H Max03-H	Max12	Max04 Max15	Max23
78205	Max01 Max02	Max09	Max10	Max01-H	Max03	Max02-H Max03-H	Max12	Max04 Max15	Max23
78215	Max01 Max02	-	-	Max01-H	Max03	Max02-H Max03-H	-	-	Max23
78220	Max01 Max02	-	Max10 Max11	Max01-H	Max03	Max02-H Max03-H	Max12	Max04 Max15	Max23
78225	Max01 Max02	-	Max10 Max11	Max01-H	Max03	Max02-H Max03-H	Max12	Max04 Max15	Max23

\* Special thick isolator clips are used to fix components with a total thickness from 7 mm or greater. For example, fastening a TO-247 device and 3mm thick ceramic insulator would result in a total thickness of 8mm. A standard Max Clip does not deform sufficiently to accommodate the total thickness. The Max23 Clip was developed to exert the necessary force in these applications.



# The Max Clip System™ Clip Index

Part Number	Normal Force 20N-40N T0-220 T0-218 T0-251 T0-262 T0-273	Short Clip T0-220 T0-218 T0-251 T0-262 T0-273	Long Clip T0-220 T0-218 T0-251 T0-262 T0-273	High Force 50N + T0-220 T0-218 T0-251 T0-262 T0-273	Normal Force 30N-50N T0-247 T0-274	High Force 60N + T0-247 T0-274 T0-3P	Sensors Small Component	Special D61 T0-247J T0-274	Special Thick Isolators Solid State Relay*
78230	Max01 Max02	-	Max10	Max01-H	Max03	Max02-H Max03-H	Max12	Max04 Max15	Max23
78245	Max01 Max02	-	-	Max01-H	Max03	Max02-H Max03-H	-	Max04 Max15	Max23
78250	Max01 Max02	Max09	-	Max01-H	Max03	Max02-H Max03-H	Max12	Max15	Max23
78255	Max01 Max02	Max09	-	-	Max03	Max02-H	-	-	Max23
78260	Max01 Max02	Max09	Max10 Max11	Max01-H	Max03	Max02-H Max03-H	Max12	Max04 Max15	Max23
78265	Max01 Max02	Max09	-	-	Max03	Max02-H	-	-	Max23
78270	Max01 Max02	Max09	-	-	Max03	Max02-H	-	-	Max23
78275	Max01 Max02	Max09	Max10	Max01-H	Max03	Max02-H Max03-H	Max12	Max04 Max15	Max23
78280	Max01 Max02	-	Max10 Max11	Max01-H	Max03	Max02-H Max03-H	Max12	Max04 Max15	Max23
78285	Max01 Max02	-	Max10 Max11	Max01-H	Max03	Max02-H Max03-H	Max12	Max04 Max15	Max23
78295	Max01 Max02	-	-	Max01-H	Max03	Max02-H Max03-H	-	-	Max23
78315	Max01 Max02	-	Max10	Max01-H	Max03	Max02-H Max03-H	Max12	Max04 Max15	Max23
78335	Max01 Max02	Max09	-	-	-	Max02-H	-	-	-
78345	Max01 Max02	-	Max10 Max11	Max01-H	Max03	Max02-H Max03-H	Max12	Max04 Max15	Max23
78350	Max01 Max02	Max09	Max10	Max01-H	Max03	Max02-H Max03-H	Max12	Max04 Max15	Max23
78355	Max01 Max02	Max09	Max10	Max01-H	Max03	Max02-H Max03-H	Max12	Max04 Max15	Max23
78360	Max01 Max02	Max09	-	-	Max03	Max02-H	-	-	Max23
78375	Max01 Max02	Max09	Max10	Max01-H	Max03	Max02-H Max03-H	Max12	Max04 Max15	Max23
78390	Max01 Max02	Max09	Max10 Max11	Max01-H	Max03	Max02-H Max03-H	Max12	Max04 Max15	Max23
78405	Max01 Max02	Max09	-	Max01-H	Max03	Max02-H Max03-H	-	-	Max23
81400	Max01 Max02	Max09	Max10 Max11	Max01-H	Max03	Max02-H Max03-H	Max12	Max04 Max15	Max23
82005	Max01 Max02	Max09	Max10 Max11	Max01-H	Max03	Max02-H Max03-H	Max12	Max04 Max15	Max23
82870	Max01 Max02	-	Max10 Max11	Max01-H	Max03	Max02-H Max03-H	Max12	Max04 Max15	Max23
82875	Max01 Max02	Max09	Max10	Max01-H	Max03	Max02-H Max03-H	Max12	Max04 Max15	Max23
82880	Max01 Max02	Max09	Max10 Max11	Max01-H Max04-H	Max03	Max02-H Max03-H	Max12	Max04 Max15	Max23
82885	Max01 Max02	Max09	-	Max01-H	Max03	Max02-H Max03-H	Max12	Max04 Max15	Max23

\* Special thick isolator clips are used to fix components and insulators with a total thickness of 7 mm or greater. For example, fastening a TO-247 device and 3mm thick ceramic insulator would result in a total thickness of 8mm. A standard Max Clip does not deform sufficiently to accommodate the total thickness. The Max23 Clip was developed to exert the necessary force in these applications.

Part Number	Normal Force 20N-40N T0-220 T0-218 T0-251 T0-262 T0-273	Short Clip T0-220 T0-218 T0-251 T0-262 T0-273	Long Clip T0-220 T0-218 T0-251 T0-262 T0-273	High Force 50N + T0-220 T0-218 T0-251 T0-262 T0-273	Normal Force 30N-50N T0-247 T0-274	High Force 60N + T0-247 T0-274 T0-3P	Sensors Small Component	Special D61 T0-247J T0-274	Special Thick Isolators Solid State Relay*
82890	Max01 Max02	Max09	-	Max01-H	Max03	Max02-H Max03-H	Max12	Max15	Max23
82895	Max01 Max02	Max09	Max10	Max01-H	Max03	Max02-H Max03-H	Max12	Max04 Max15	Max23
82900	Max01 Max02	Max09	-	Max01-H	Max03	Max02-H Max03-H	Max12	Max15	Max23
82905	Max01 Max02	Max09	Max10	Max01-H	Max03	Max02-H Max03-H	Max12	Max15 Max15	Max23
82910	Max01 Max02	-	Max10 Max11	Max01-H	Max03	Max02-H Max03-H	Max12	Max04 Max15	Max23
82920	Max01 Max02	-	Max10 Max11	Max01-H	Max03	Max02-H Max03-H	Max12	Max04 Max15	Max23
82925	Max01 Max02	Max09	-	-	Max03	Max02-H	-	-	Max23
82930	Max01 Max02	-	Max10 Max11	Max01-H	Max03	Max02-H Max03-H	Max12	Max04 Max15	Max23
82935	Max01 Max02	-	Max10 Max11	Max01-H	Max03	Max02-H Max03-H	Max12	Max04 Max15	Max23
82940	Max01 Max02	-	Max10 Max11	Max01-H	Max03	Max02-H Max03-H	Max12	Max04 Max15	Max23
82945	Max01 Max02	Max09	-	Max01-H	Max03	Max02-H Max03-H	Max12	Max15	Max23 Max23
82950	Max01 Max02	-	Max10 Max11	Max01-H	Max03	Max02-H Max03-H	Max12	Max04 Max15	Max23
82955	Max01 Max02	Max09	Max10	Max01-H	Max03	Max02-H Max03-H	Max12	Max04 Max15	Max23
82960	Max01 Max02	Max09	Max10 Max11	Max01-H	Max03	Max02-H Max03-H	Max12	Max04 Max15	Max23
82965	Max01 Max02	Max09	Max10 Max11	Max01-H	Max03	Max02-H Max03-H	Max12	Max04 Max15	Max23
82970	Max01 Max02	Max09	-	-	-	Max02-H	-	-	-
82975	Max01 Max02	Max09	Max10 Max11	Max01-H	Max03	Max02-H Max03-H	Max12	Max04 Max15	
82980	Max01 Max02	Max09	-	-	Max03	Max02-H	-	-	Max23
82985	Max01 Max02	-	Max10 Max11	Max01-H	Max03	Max02-H Max03-H	Max12	Max04 Max15	Max23
82990	Max01 Max02	Max09	Max10 Max11	Max01-H	Max03	Max02-H Max03-H	Max12	Max04 Max15	Max23
83000	Max01 Max02	Max09	Max10	Max01-H	Max03	Max02-H Max03-H	Max12	Max04 Max15	Max23
83005	Max01 Max02	-	Max10 Max11	Max01-H	Max03	Max02-H Max03-H	Max12	Max04 Max15	Max23
83010	Max01 Max02	-	Max10 Max11	Max01-H	Max03	Max02-H Max03-H	Max12	Max04 Max15	Max23
83015	Max01 Max02	-	Max10 Max11	Max01-H	Max03	Max02-H Max03-H	Max12	Max04 Max15	Max23
83020	Max01 Max02	-	Max10 Max11	Max01-H	Max03	Max02-H Max03-H	Max12	Max04 Max15	Max23

\* Special thick isolator clips are used to fix components and insulators with a total thickness of 7 mm or greater. For example, fastening a TO-247 device and 3mm thick ceramic insulator would result in a total thickness of 8mm. A standard Max Clip does not deform sufficiently to accommodate the total thickness. The Max23 Clip was developed to exert the necessary force in these applications.

# The Max Clip System™ Standard Clips

THE MAX CLIP SYSTEM™ CLIPS

<b>Max01</b>	Width	Thickness	Force
	10 mm	x 0.5	= 22 N

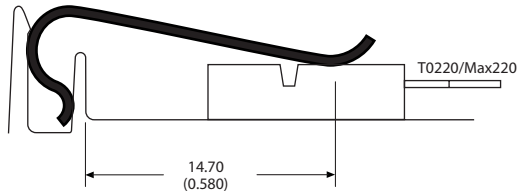

<b>Max02</b>	Width	Thickness	Force
	12 mm	x 0.5	= 35 N

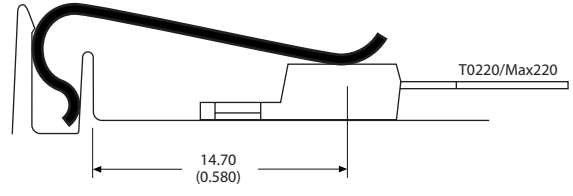

<b>Max03</b>	Width	Thickness	Force
	15 mm	x 0.5	= 45 N

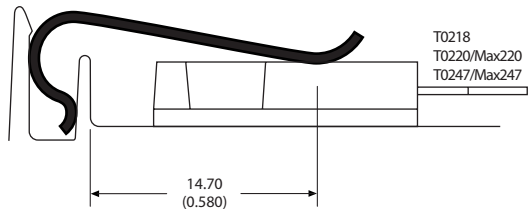

<b>Max04</b>	Width	Thickness	Force
	20 mm	x 0.5	= 60 N

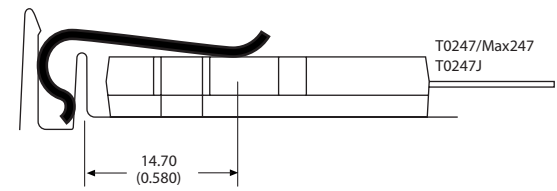

<b>Max07</b>	Width	Thickness	Force
	12 mm	x 0.6	= 50 N

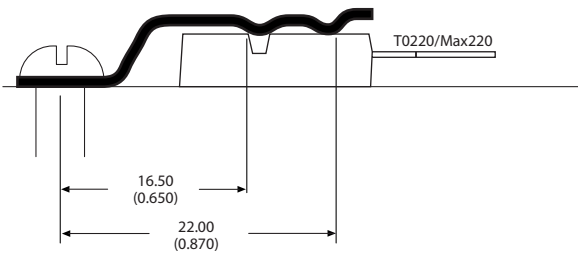

With Screws

<b>Max08</b>	Width	Thickness	Force
	18 mm	x 0.6	= 75 N

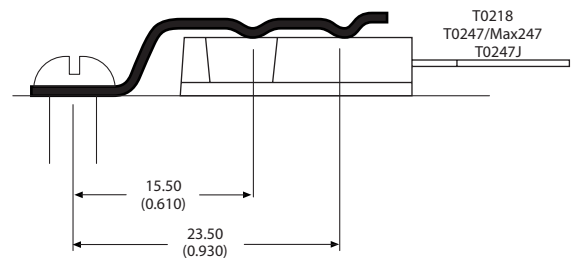

With Screws

<b>Max09</b>	Width	Thickness	Force
	10 mm	x 0.5	= 45 N

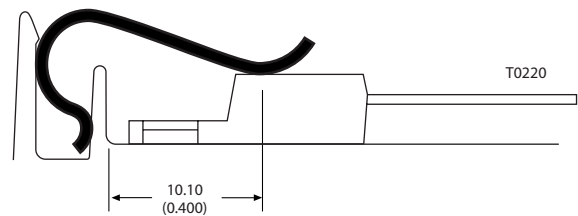

<b>Max10</b>	Width	Thickness	Force
	12 mm	x 0.6	= 40 N

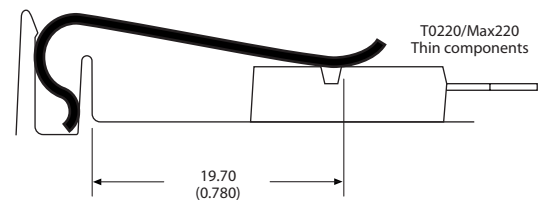

<b>Max11</b>	Width	Thickness	Force
	12 mm	x 0.6	= 35 N

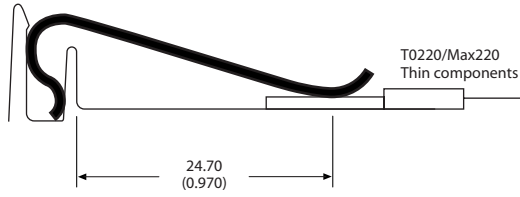

<b>Max12</b>	Width	Thickness	Force
	6 mm	x 0.6	= 25 N

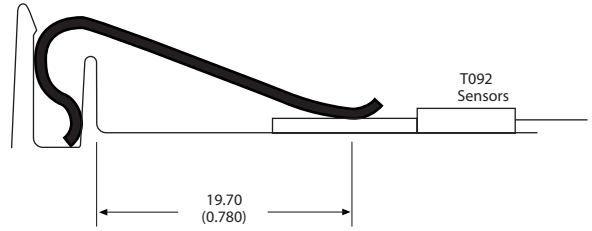

<b>Max13</b>	Width	Thickness	Force
	17 mm	x 0.5	= 45 N

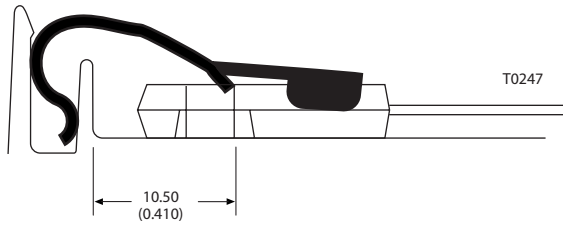

<b>Max14</b>	Width	Thickness	Force
	13 mm	x 0.5	= 20 N

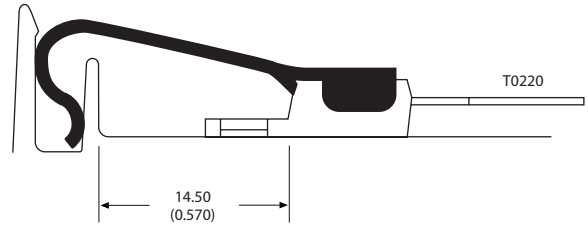

<b>Max15</b>	Width	Thickness	Force
	18 mm	x 0.6	= 60 N

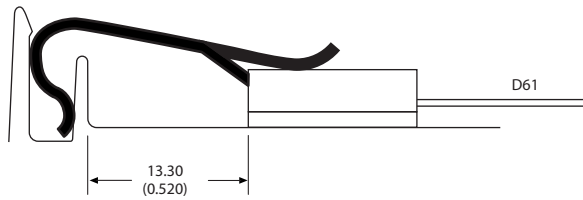

<b>Max23</b>	Width	Thickness	Force
	18 mm	x 0.6	= 100 N

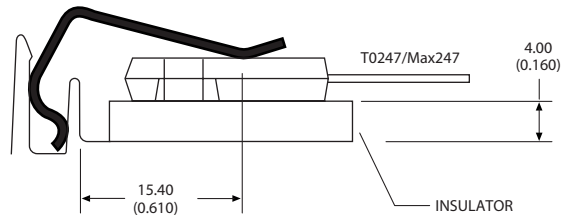

<b>Max01-H</b>	Width	Thickness	Force
	10 mm	x 0.7	= 80 N

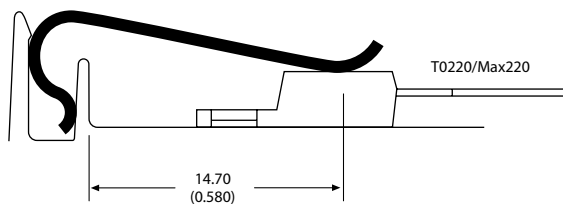

H = High Force

<b>Max02-H</b>	Width	Thickness	Force
	13 mm	x 0.6	= 60 N

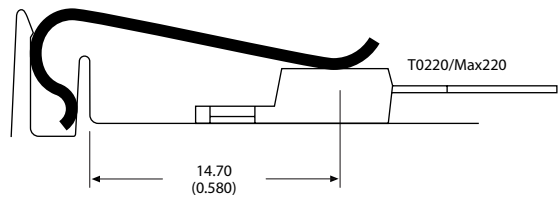

H = High Force

<b>Max03-H</b>	Width	Thickness	Force
	18 mm	x 0.6	= 80 N

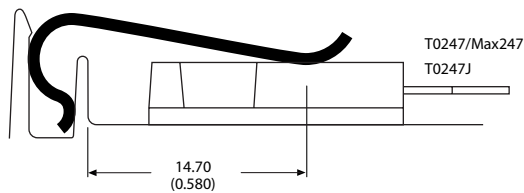

H = High Force

# The Max Clip System™ U-Clips

U-Clips can be used to attach semiconductors to conventional extrusions or plates. These clips provide the necessary force to maintain proper thermal performance.

<b>CLP212</b>	Width	Thickness	Force
	10.1 mm	x 0.5	= 21 N

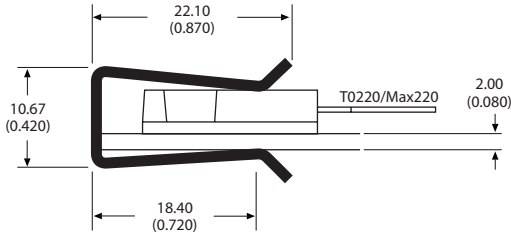

<b>CLP212M</b>	Width	Thickness	Force
	15 mm	x 0.5	= 36 N

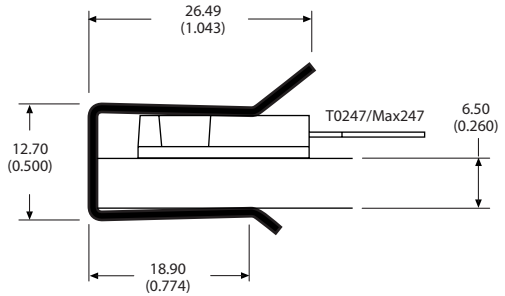

<b>CLP212P</b>	Width	Thickness	Force
	10 mm	x 0.5	= 21 N

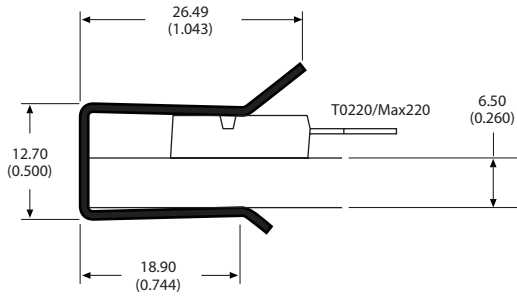

<b>CLP212S</b>	Width	Thickness	Force
	7 mm	x 0.5	= 20 N

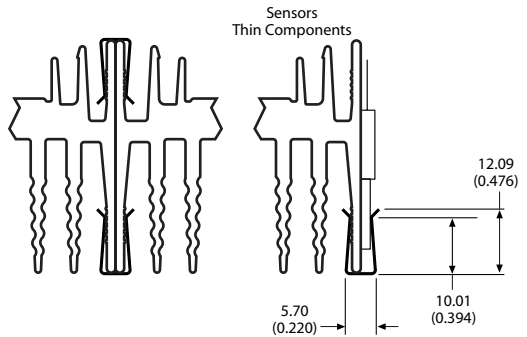

<b>CLP212T</b>	Width	Thickness	Force
	10 mm	x 0.6	= 34 N

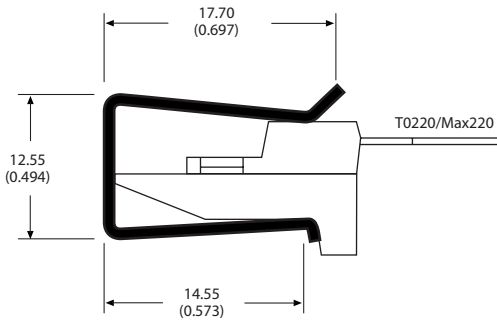

THE MAX CLIP SYSTEM™ CLIPS

Below are examples of Assembly Ideas, using Aavid Thermalloy's Max Clip System™. The illustrations show the use of multi-ple extrusion profiles, fans and clips to assemble cost effective high performance thermal solutions. Please contact Aavid application engineering to discuss developing assembly configurations specific to your application.

**Forced Convection Assemblies (using customer supplied fans)**

**78030** Extrusion with fan  $\theta_f = 0.36\text{ }^\circ\text{C/W}$

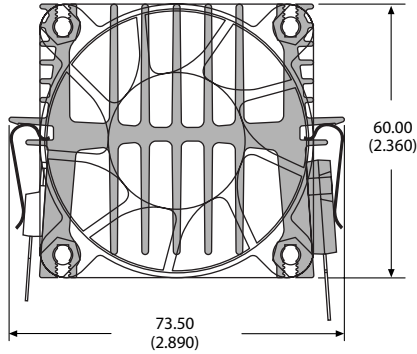

**78080** 8 Piece extrusion with fan  $\theta_f = 0.069\text{ }^\circ\text{C/W}$

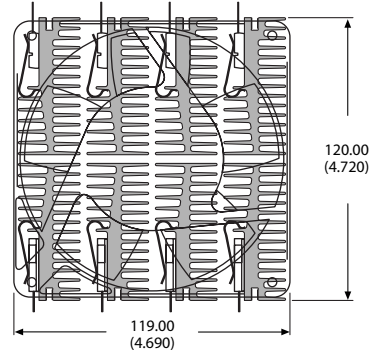

**78345** Extrusion with fan  $\theta_f = 0.49\text{ }^\circ\text{C/W}$

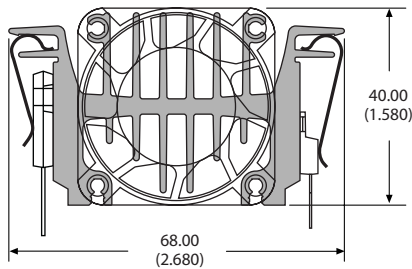

**78010** 8 Piece extrusion with fan  $\theta_f = 0.049\text{ }^\circ\text{C/W}$

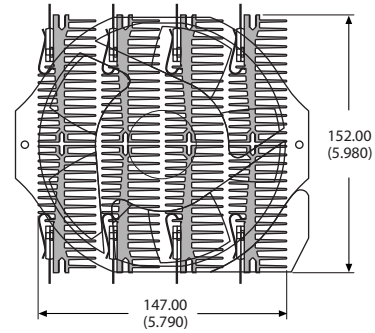

**Max Heat Connector Assemblies**

**78315** Max heat sink support

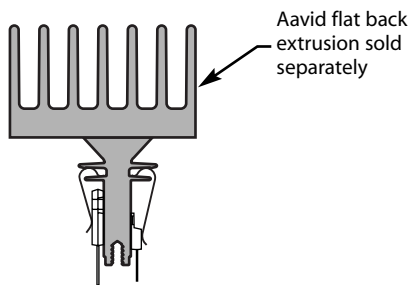

**78085** Max heat sink support

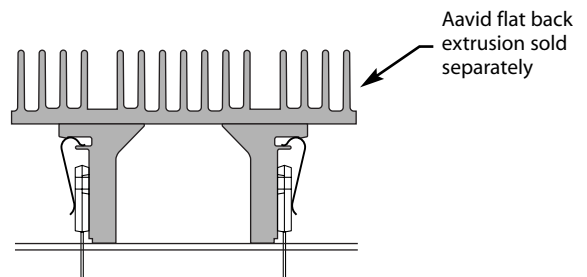

**Connecting Max Profiles with U-Clips**

**78045** Extrusion with Clip CLP212S

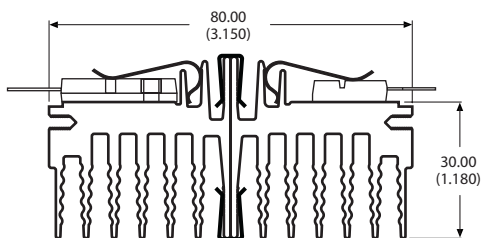

## Semi-Automated Assembly (1)

One way of optimizing The Max Clip System™ for volume manufacturing is through the use of semi-automated assembly. The Max Clip System™ is suitable for pick and place machines and the following diagrams illustrate a method for automating the semiconductor and clip attachment to Max Extrusions.

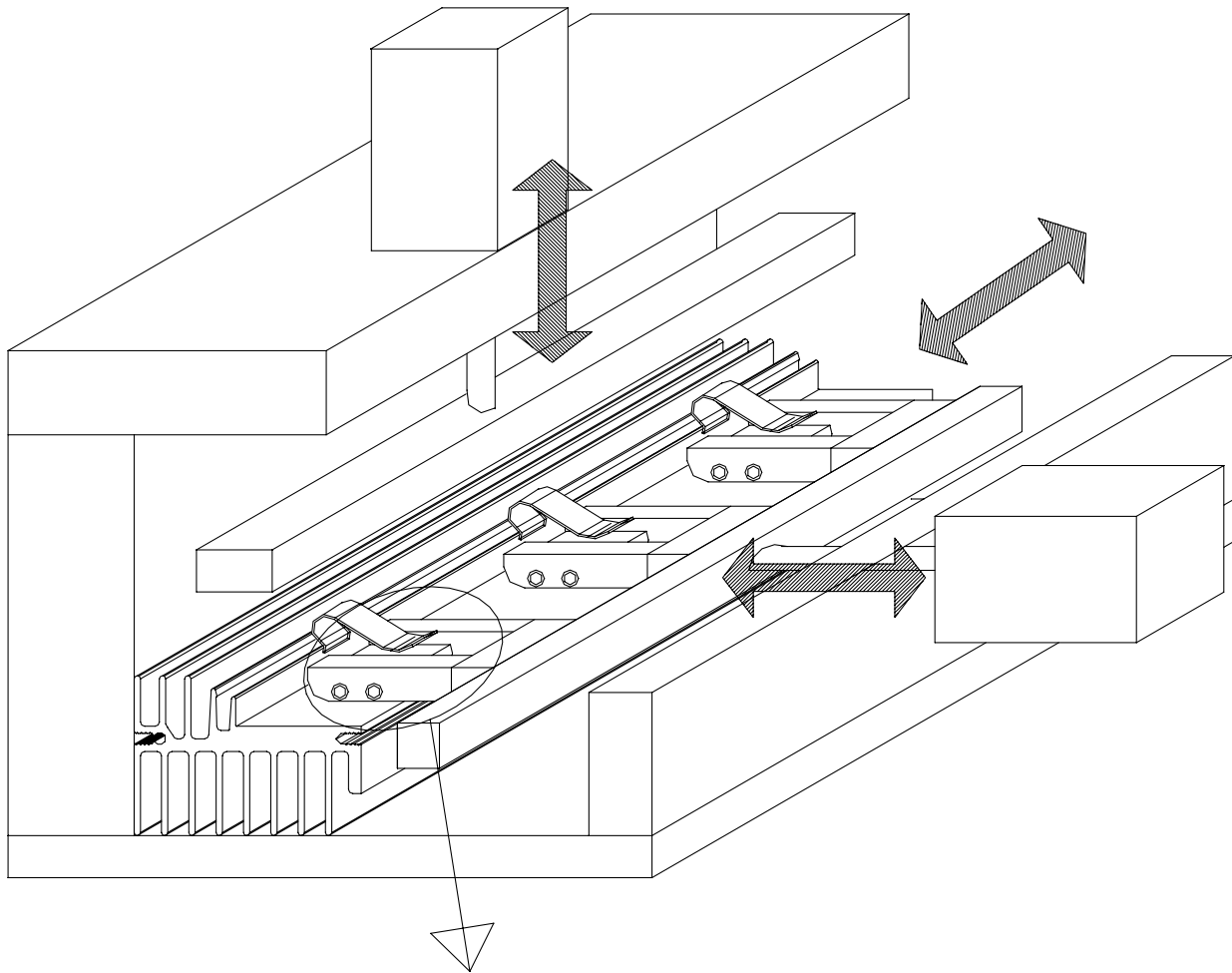

**DETAIL OF COMPONENT LOCATOR INSERT**

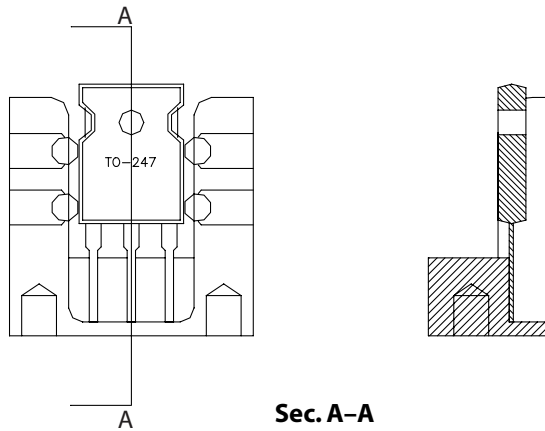

HEAT SINK LOCATING

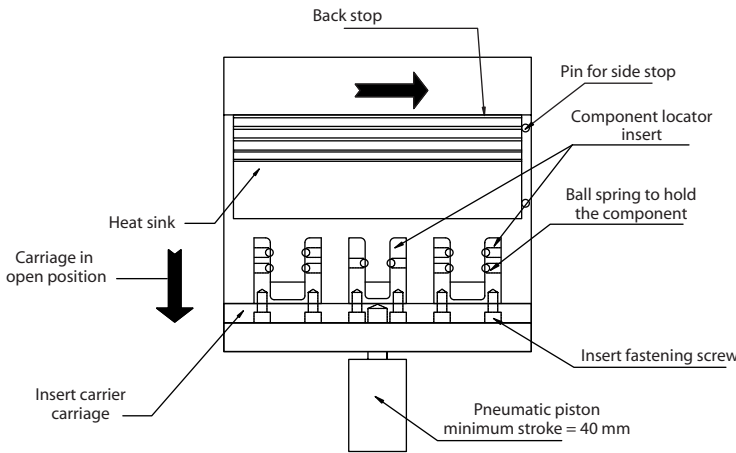

CLIP PRESSING

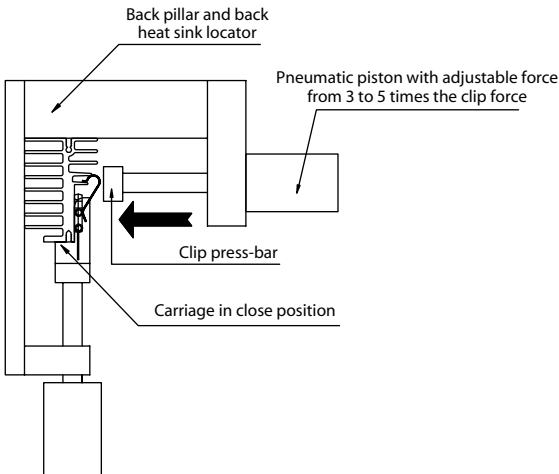

COMPONENTS AND CLIP LOCATING

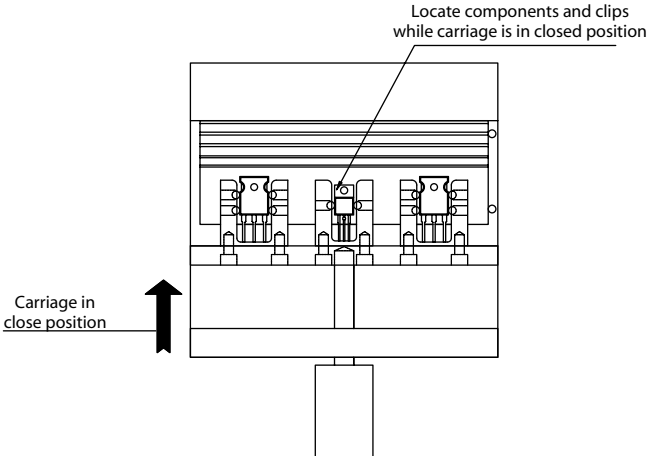

HEAT SINK REMOVAL

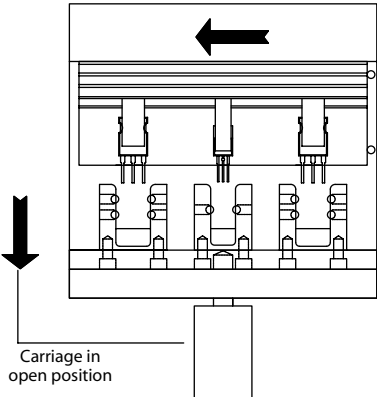



## 78065 Indian Chief Profiles (TO-220, T0-252, TO-262)

kg/m: 0.493 •  $\Theta_n = 2.15 \text{ }^\circ\text{C/W} \cdot \Theta_f = 0.73 \text{ }^\circ\text{C/W}$

Max Indian Chief styles use a unique extrusion profile with an integrated clip. The Indian Chief shares all the advantages of The Max Clip System™ without the use of a discrete clip. The profiles are compact and suited for board level cooling requirements. These profiles are designed to accept packages with or without mounting tabs.

CHIEF EXTRUSION PROFILES

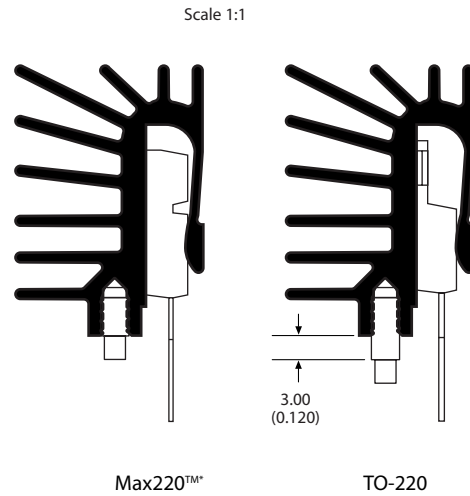
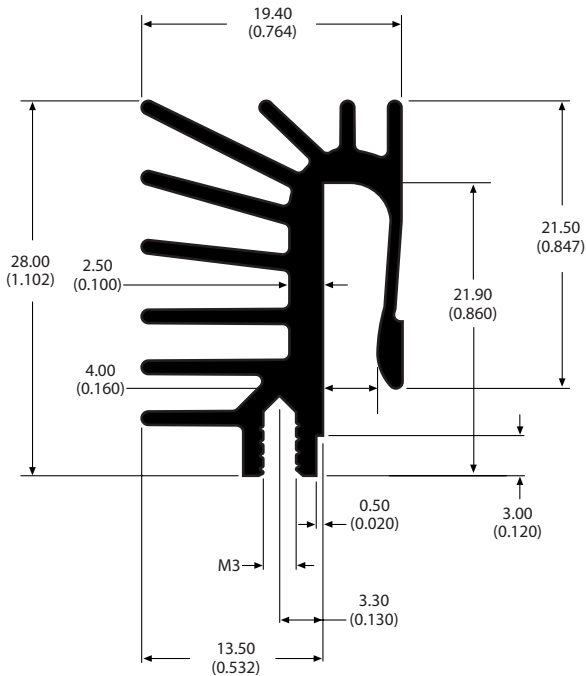

See page 34 for options on solderable pins

### Black anodized heat sink thermal resistance (°C/W)

Part number	Length	Natural convection	Forced convection			Force on component (N)
			1 m/s	2 m/s	3 m/s	
780653B00590	15(0.590)	13.31	5.46	4.09	3.35	54
780653B00790	20 (0.790)	10.66	4.30	3.20	2.60	70
780653B00980	25 (0.980)	8.97	3.58	2.65	2.15	85
780653B01180	30 (1.18)	7.77	3.08	2.27	1.84	100

### Unfinished heat sink thermal resistance (°C/W)

Part number	Length	Natural convection	Forced convection			Force on component (N)
			1 m/s	2 m/s	3 m/s	
780653U00590	15 (0.59)	16.18	6.05	4.41	3.56	54
780653U00790	20 (0.790)	13.02	4.76	3.44	2.77	70
780653U00980	25 (0.98)	10.98	3.96	2.85	2.28	85
780653U01180	30 (1.18)	9.55	3.41	2.45	1.96	100

The heat sink thermal performance is evaluated in the vertical mode at a  $\Delta T$  of 70°C.

\* Max220™ is a registered trademark of STMicroelectronics

**78240 Big Chief Profiles (TO-247, TO-218)**

kg/m: 0.627 •  $\theta_n = 1.74$  °C/W •  $\theta_f = 0.58$  °C/W

Max Big Chief styles use a unique extrusion profile with an integrated clip. The Big Chief shares all the advantages of The Max Clip System™ without the use of a discrete clip. The profiles are compact and suited for board level cooling requirements. These profiles are designed to accept packages with or without mounting tabs.

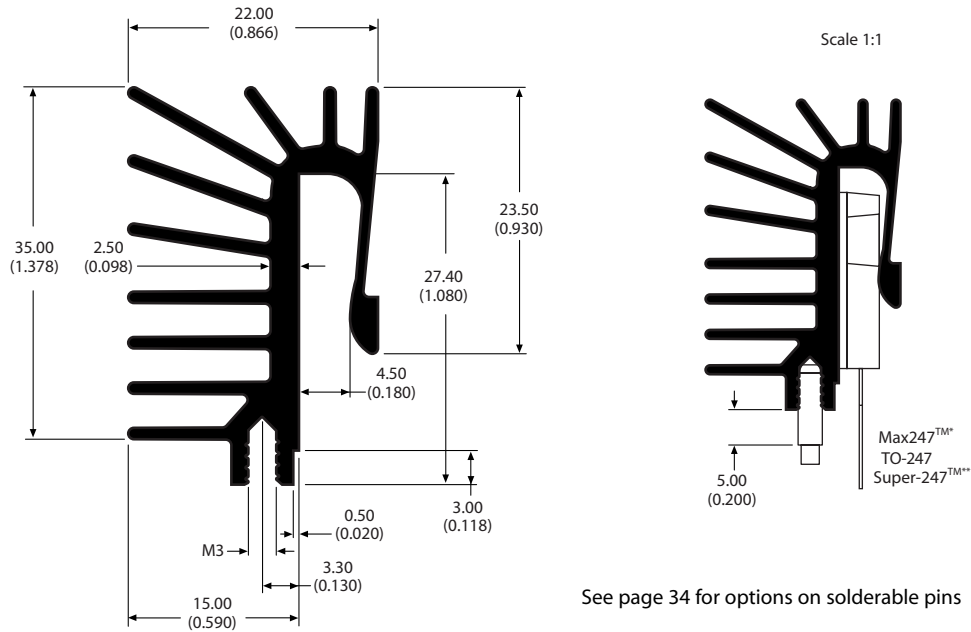

See page 34 for options on solderable pins

**Black anodized heat sink thermal resistance (°C/W)**

Part number	Length	Natural convection	Forced convection			Force on component (N)
			1 m/s	2 m/s	3 m/s	
782403B00590	15 (0.590)	10.71	4.49	3.40	2.80	54
782403B00790	20 (0.790)	8.58	3.53	2.65	2.17	70
782403B00980	25 (0.980)	7.22	2.93	2.19	1.79	85
782403B01180	30 (1.18)	6.26	2.53	1.88	1.53	100

**Unfinished heat sink thermal resistance (°C/W)**

Part number	Length	Natural convection	Forced convection			Force on component (N)
			1 m/s	2 m/s	3 m/s	
782403U00590	15 (0.590)	12.96	5.02	3.69	2.99	54
782403U00790	20 (0.790)	10.42	3.94	2.88	2.32	70
782403U00980	25 (0.980)	8.79	3.28	2.38	1.91	85
782403U01180	30 (1.18)	7.66	2.82	2.04	1.68	100

The heat sink thermal performance is evaluated in the vertical mode at a  $\Delta T$  of 70°C.

\* Max247™ is a registered trademark of STMicroelectronics  
 \*\* Super-247™ is a registered trademark of International Rectifier

How to add solderable pins for easy attachment in circuit board applications

The Max Clip System™ can be mounted directly to printed circuit boards by installing tin plated pins in the base of the heat sink and then creating a pattern of plated through holes in the circuit card to accept the pins. The heat sink assembly can then be inserted into the circuit board holes and soldered into place during wave solder operations. These pins come in a variety of stand-off lengths as illustrated below. Since placement of the pins is specific to the application, a customer supplied drawing is required when ordering. The drawing should contain the information shown in Figure A.

Pin Dimensions

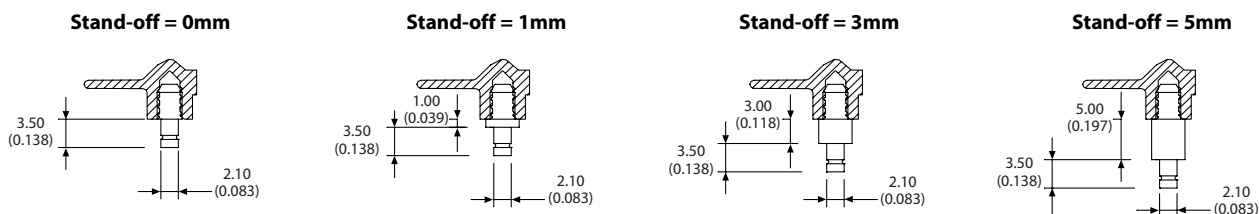
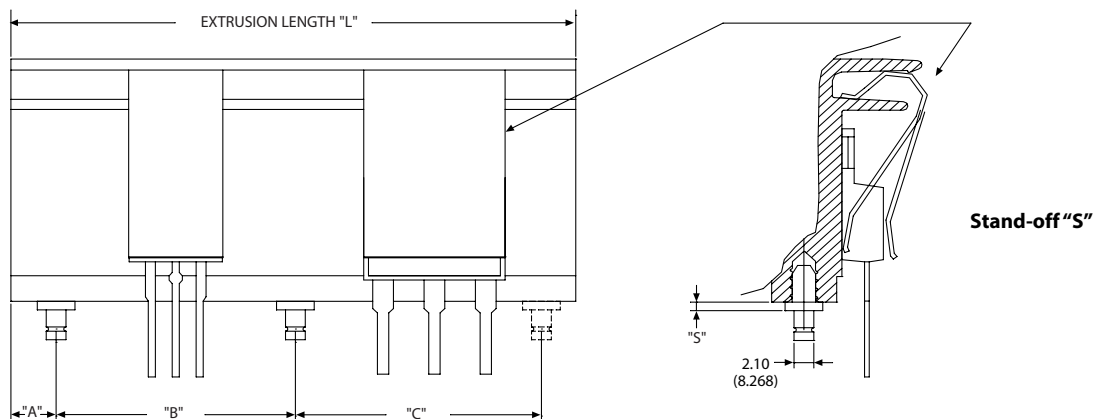

Figure A

The Max Clip System™

View from component side



The suggested hole dia. in the PCB is  $2.7 \pm 0.1$  mm with a pitch tolerance of  $\pm 0.15$  mm.

Dimensions "B" and "C" are not required for a heat sink with only 1 solderable pin  
 Dimension "C" is not required for a heat sink with 2 solderable pins  
 Tolerance  $\pm 0.2$  mm

- Standard Stand-off = 0 mm
- 1 mm
- 3 mm
- 5 mm

NOTE: We suggest that soldering and mechanical resistance tests are made by customer before full production.

THERMAL RESISTANCE vs LENGTH

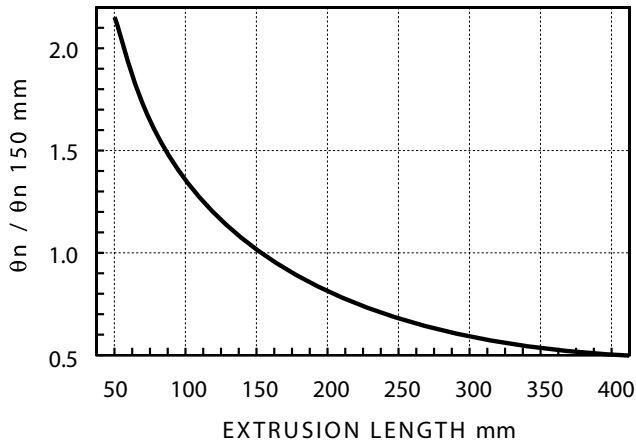

THERMAL RESISTANCE vs (Ts - Ta)

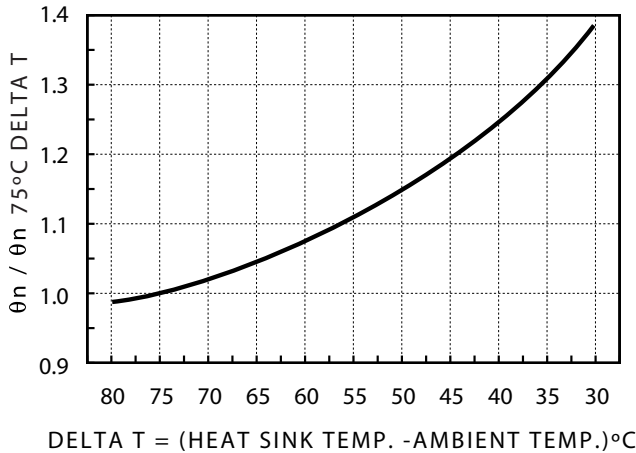

THERMAL RESISTANCE vs AIR SPEED

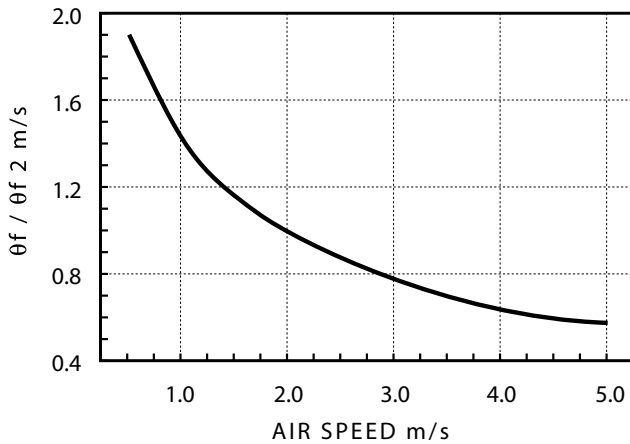

**HOW TO INTERPRET THERMAL PERFORMANCE**

The extrusions are presented in order by shape and size. Dimensions are in mm with (inches) following in parenthesis. On pages 5-6 there is an index sorted by extrusion part number. The part number, weight in kg/m, thermal resistance ( $\theta_n$  with natural convection, thermal resistance  $\theta_f$  with forced convection) at an air speed of 2.0 m/s is shown for each extrusion. The thermal resistances have been calculated using 150 mm long vertical anodized heat sinks with a sink-to-ambient temperature difference of 75°C and a uniform thermal load on the heat sink base.

**LENGTH CORRECTION FACTOR**

Because the air heats up while circulating through the extrusion, the convection coefficient is not constant throughout the extrusion length. Therefore, the thermal resistance changes nonlinearly as the length changes. To calculate the correct thermal resistance for extrusion lengths other than the standard 150 mm length, multiply the given thermal resistance data by the appropriate factor taken from the thermal resistance vs length graph shown. The same correction factor must be used for thermal resistance in both natural convection and forced convection.

**TEMPERATURE CORRECTION FACTOR**

Both natural convection and radiation coefficients are related to the sink-to-ambient temperature difference. To evaluate the thermal performance of a heat sink for an application requiring a sink-to-ambient temperature rise other than 75°C, use the correction factor from the thermal resistance vs (Ts - Ta) graph shown. This factor must be used only for thermal resistance in natural convection.

**AIR SPEED CORRECTION FACTOR**

The convection coefficient is also closely related to the air speed through the fins. Since evaluation of air speed through the fins is difficult to evaluate under normal circumstances, we show the thermal resistance of an extrusion in forced convection evaluated using a tunnel the same size as the extrusion. For a tunnel airflow other than 2 m/s, refer to the factor in the thermal resistance vs air speed graph shown. Use this factor to figure thermal resistance in forced convection.

Provided by PENNY + GILES • Test Certificate No. 3318

## 1. TEST CONDUCTED

1.1 Sine Vibration and 1/2 Sine Shock

## 2. SPECIMEN DATA

2.1 No. Off: 4 off  
2.2 Identification: Heat sink S509/40 with MAX Clips retaining 4 off semiconductors  
2.3 Reference No.(s): MAX 01, MAX 02, MAX 03, MAX 04  
2.4 Serial No.(s): 1, 2, 3, and 4  
2.5 Condition received: OK

## 3. SPECIFICATIONS AND/OR NATIONAL STANDARDS

3.1 Equipment Specification

3.1.1 Authority: N/A  
3.1.2 Title: N/A  
3.1.3 Issue: N/A  
3.1.4 Data: N/A  
3.1.5 Requirements: N/A

3.2 RELATED NATIONAL STANDARD

3.2.1 Authority: BSI  
3.2.2 Title: BS2011  
3.2.3 Issue: As date  
3.2.4 Data: Test Ea: 1988, Test Fc: 1983.  
3.2.5 Requirement(s): Tests Ea and Fc, as modified by Request To Test form 3318

## 4. CLIENT

4.1 El.Bo.Mec Thermalloy - Via Del Tipografo, 4 - 40138 Bologna, Italy

## 5. RECEIPT OF TEST SPECIMEN

5.1 Specimen received 28.05.98 under request to test form No. 3318, dated 28.05.98.

## 6. DATE OF TEST

6.1 Test commenced and completed 01.06.98.

## 7. DISPOSAL OF TEST SPECIMEN

7.1 Specimen returned to client under delivery note 1362 dated 02.06.98.

## 8. TEST METHOD/PROCEDURE

8.1 The heat sink assembly was mounted onto the shaker table and subjected to a sinusoidal vibration test as follows:

Frequency Range: 8 Hz to 100 Hz  
Vibration Amplitude:  $\pm 3g$  pk  
Rate of Change of Frequency: 1 Octave per minute  
Test Duration: 20 minutes

8.2 During the above 20 minute period the heat sink assembly was observed visually for evidence of the max mounts becoming detached.

8.3 The procedures described in 8.1 and 8.2 above were repeated such that vibration test was conducted in all three mutually perpendicular axes.

8.4 The heat sink assembly was then subjected to a shock test as follows:

Shock Pulse Envelope: 112 sine  
Period: 6 ms  
Amplitude: 5 g  
Number of Shocks: 3  
Application: 3 shocks per sense per axis

8.5 During the above 20 minute period the heat sink assembly was observed visually for evidence of the max mounts becoming detached.

## 9. TEST RESULTS

9.1 The max clips did not break free from the heat sink assembly. No physical degradation was observed.

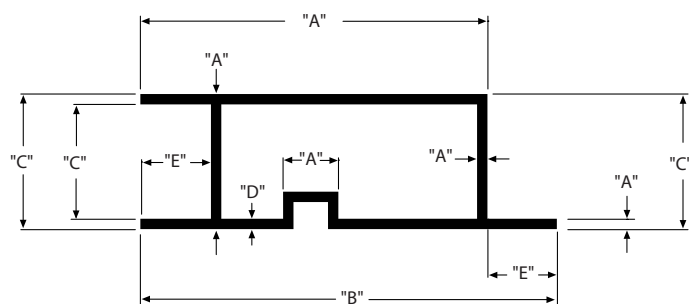

- (1) for "A" Dim or "B" Dim = 300 mm tolerances supplied by customer
- (2) for "E" Dim = 5 mm, tolerances equal "B"

"A" Dim or "B" Dim (mm)	Tolerances (mm)
< "A" or "B" = 2	± 0.15
2 < "A" ≤ 3	± 0.20
3 < "A" ≤ 5	± 0.25
5 < "A" ≤ 10	± 0.30
10 < "A" ≤ 15	± 0.35
15 < "A" ≤ 30	± 0.40
30 < "A" < 50	± 0.50
50 < "A" < 80	± 0.80
80 < "A" < 100	± 1.00
100 < "A" ≤ 120	± 1.20
120 < "A" ≤ 150	± 1.30
150 < "A" ≤ 200	± 1.50
200 < "A" ≤ 250	± 1.80
250 < "A" ≤ 300	± 2.10

"D" Dim (mm)	Tolerances (mm)
< 2.5	± 0.25
= 2.5	± 10%

"C" Dim (mm)	Tolerances (mm)			
	5 < "E" ≤ 15	15 < "E" ≤ 30	30 < "E" ≤ 60	"E" ≤ 60
"C" = 5	± 0.30	± 0.35	± 0.40	± 0.50
5 < "C" < 10	± 0.35	± 0.40	± 0.45	± 0.55
10 < "C" < 15	± 0.40	± 0.45	± 0.50	± 0.65
15 < "C" ≤ 20	± 0.45	± 0.50	± 0.60	± 0.75
20 < "C" ≤ 30	± 0.50	± 0.60	± 0.75	± 0.90
30 < "C" < 50	± 0.60	± 0.75	± 0.90	± 1.30
50 < "C" < 70	± 0.85	± 0.95	± 1.10	± 1.45
70 < "C" ≤ 100	± 1.05	± 1.10	± 1.25	± 1.65
100 < "C" ≤ 150	± 1.35	± 1.40	± 1.65	± 2.20
150 < "C" ≤ 200	± 1.50	± 1.60	± 2.00	± 2.80
200 < "C" < 250	± 1.85	± 1.90	± 2.55	± 3.50
250 < "C" < 300	± 2.20	± 2.40	± 3.20	± 4.00

Machining Standard Tolerances		UNI-ISO 2768 m
Cut to length	L < 300	± 0.25
	300 ≤ L < 500	± 0.5
	L = 500	± 1.0
Hole center to center	"D" < 30	± 0.2
	30 ≤ "D" < 120	± 0.3
	120 ≤ "D" < 400	± 0.5
	"D" = 400	± 0.8
Hole Diameter	"D" < 8	-0.05 + 0.08
Unmachined surfaces	Flatness	0.5 / 100
	Roughness	1.6 μm
Machined surfaces	Flatness	0.05 / 100
	Roughness	0.8 ~ μm
Anodization thickness	12 μm	± 5 μm

Parameters	Tolerance (mm)	
	Size	Maximum depth
Threaded holes maximum depth	M2	6
	M2.5	7.5
	M3	10
	M4	12
	M5	15
	M6	18
	M8	24

Parameter	Quantity (q)	Tolerance
Quantity	q < 10	- 1 pc
	10 ≤ q < 50	± 1 pc
	50 ≤ q < 200	± 2 pcs
	200 < q < 500	± 5 pcs
	500 < q < 100	± 10 pcs
	q = 1000	± 30 pcs

Our products are typically made using **Al 6060 T5** (Aluminum Alloy 9006/1).